

NEP Compact Busbar Trunking Systems

أنظمة توصيلات قضيب التوزيع المدمجة

Low Power

الطاقة المنخفضة

DEKRA KEMA



LOW POWER

(40A - 63A - 100A) The conductors used in this serie are CUPONAL™

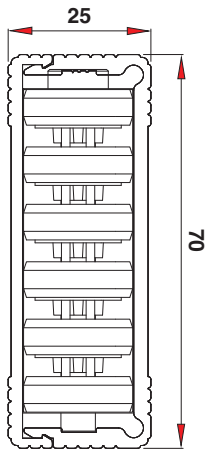

40A 6mm x 3mm
CUPONAL™ Bar's

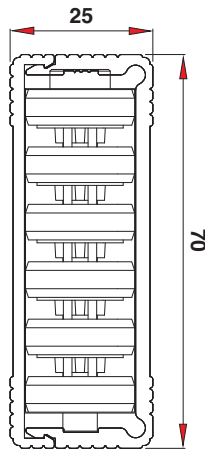

63A 8mm x 3mm
CUPONAL™ Bar's

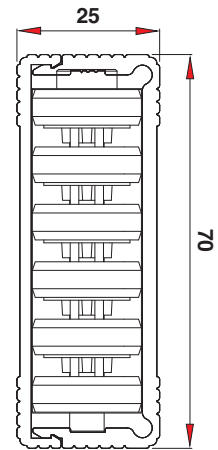

100A 6mm x 3mm
CUPONAL™ Bar's

LOWPOWER BUSBAR TRUNKING SYSTEMS:

Lighting Busbar Systems: Lighting busbars are the systems designed for supplying lighting armatures inside the facilities. Installation, maintenance, automation and displacement of these armatures are very practical and easy.

Lighting units are supplied by means of armature outlet plugs mounted to the outlets over the body of busbar. Phase grouping or balanced loading possibility is provided by selecting outlet plug belonging to the appropriate phase order. In addition, armatures can be moved with busbar body by means of Simple and modular armature hanger clips. LOWPOWER Lighting distribution busbars are manufactured in current values between 40 A. and 100 A

LOWPOWER is more than a lighting busbar system. When it is supported with MDA AUTOMATION SYSTEM, a high level efficiency emerges.

As efficiency of armatures used for the lighting of buildings is provided through LED technology, efficiency can be increased thanks to automation by controlling these systems with cabled systems.

LOWPOWER has the capability of applying automation without using cable. While receivers of LOWPOWER are energized by means of outlet plugs having a capacity of 10 Amperes and outlet box having a capacity of 32-80 Amperes; at the same time, it has such a technology that can perform Wi-Fi automations of these.

LOWPOWER offers 3 options from 40 Amperes to 100 Amperes. These options are selected and applied according to the load of the line. Accessories used for these 3 options in LOWPOWER system are compatible with each other and installation can also be made without any necessity to any other accessories.

Phase option is available in LOWPOWER current receiving options. When required, single phase and 3 phase current can be received from same plug. As outlet plugs are being used without fuse, outlet boxes are designed pursuant to mount 6-80 Amperes W automat.

LOWPOWER 63 and 100 Amperes, if required, can be used for supplying power and junction energy in elevated pavement systems. Also in these systems, power points can be got kept under control by performing automation by means of MDA AUTOMATION SYSTEM.

LOWPOWER is manufactured of light aluminum case. Its body is taken under protection by coating it with anodic in order not to be affected from corrosion. The system is designed as appropriate to the Horizontal and Vertical installation and in compliance with project modifications.

CUPONAL™ Bars are used as conductive in LOWPOWER Busbar Systems.

LOWPOWER has KEMA Quality Test Certificates- KEMA Quality Test Reports and DEKRA Quality Test Certificates- DEKRA Quality Test Reports certificates in the standard of IEC 61439-6/2012 under all amperages.

• NEP Busbar Systems passed the tests below successfully. .

NEP Compact Busbar Trunking Systems

أنظمة توصيلات قضيب التوزيع المدمجة

Low Power

الطاقة المنخفضة

DEKRA KEMA

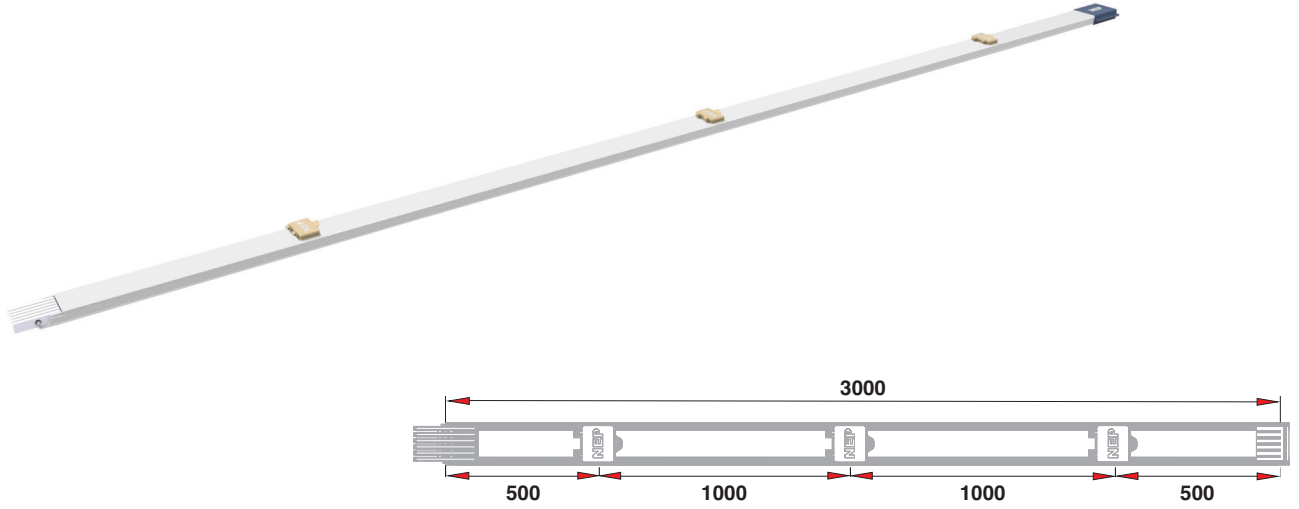

X=min.350 mm

STANDART LENGHT ELEMENT P+N+Pec

عنصر مزود بمسماار خاص PE+N+P3

Standart Lenght Element (Cu+Al)

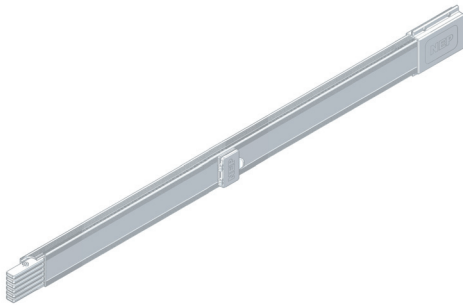

Rated (A) مقدر (أمبير)	Length (mm) الطول (مم)	Order No رقم الطلب	Pcs. القطع	Weight (Kg) الوزن (كغم)
Composite (Cu+Al)				
LOW 40	3000	AS-L-CP 5530400STD	1 unit	4,60
LOW 63	3000	AS-L-CP 5530630STD	1 unit	5,00
LOW 100	3000	AS-L-CP 5531000STD	1 unit	5,40

STANDART LENGHT ELEMENT 3P+N+Pec

عنصر مزود بمسماار خاص PE+N+P3

Standart Lenght Element (Cu+Al)



Rated (A) مقدر (أمبير)	Length (mm) الطول (مم)	Order No رقم الطلب	Pcs. القطع	Weight (Kg) الوزن (كغم)
Composite (Cu+Al)				
LOW 40	3000	AS-L-CP 5550400STD	1 unit	5,00
LOW 63	3000	AS-L-CP 5550630STD	1 unit	5,50
LOW 100	3000	AS-L-CP 5551000STD	1 unit	6,00

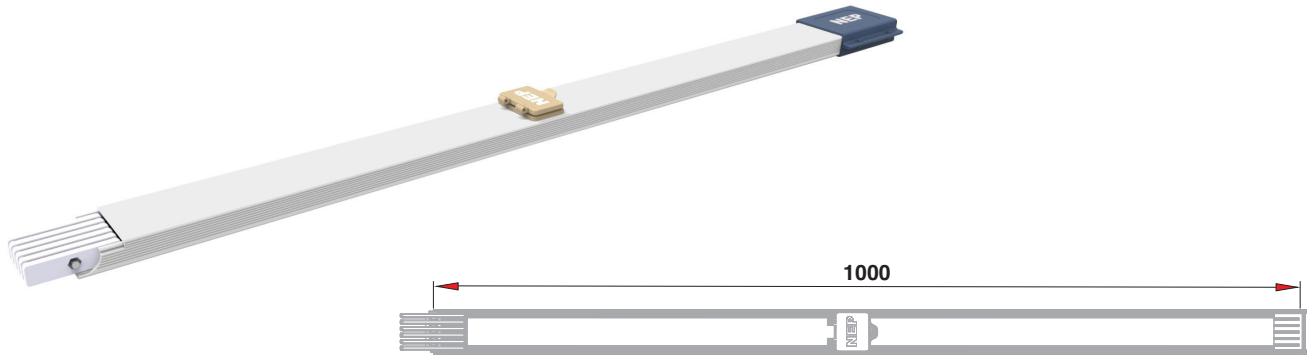

X=min.350 mm

NON-STANDART LENGHT ELEMENT P+N+Pec

عنصر مزود بمسمار خاص PE+N+P3

Standart Element Plug-in (Cu+Al)



Rated (A) مقدراً (أمبير)	Length (mm) الطول (مم)	Order No رقم الطلب	Pcs. القطع	Weight (Kg) الوزن (كغم)
Composite (Cu+Al)				
LOW 40	3000	AS-L-CP 5530400XXX	1 unit	1,45
LOW 63	3000	AS-L-CP 5530630XXX	1 unit	1,80
LOW 100	3000	AS-L-CP 5531000XXX	1 unit	2,00

NON-STANDART LENGHT ELEMENT 3P+N+Pec

عنصر مزود بمسمار خاص PE+N+P3

Non-Standart Lenght Element (Cu+Al)

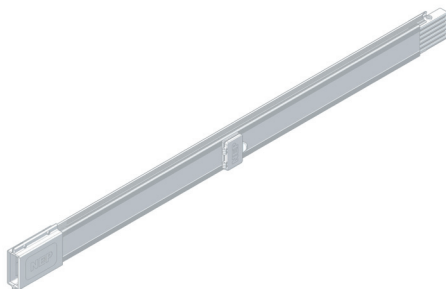

Rated (A) مقدراً (أمبير)	Length (mm) الطول (مم)	Order No رقم الطلب	Pcs. القطع	Weight (Kg) الوزن (كغم)
Composite (Cu+Al)				
LOW 40	3000	AS-L-CP 5550400XXX	1 unit	1,75
LOW 63	3000	AS-L-CP 5550630XXX	1 unit	2,00
LOW 100	3000	AS-L-CP 5551000XXX	1 unit	2,25

NEP Compact Busbar Trunking Systems

أنظمة توصيلات قضيب التوزيع المدمجة

Low Power

الطاقة المنخفضة

DEKRA KEMA

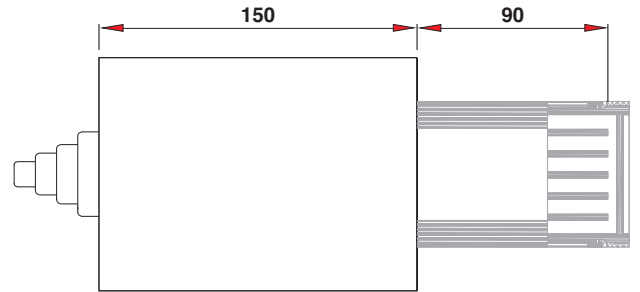
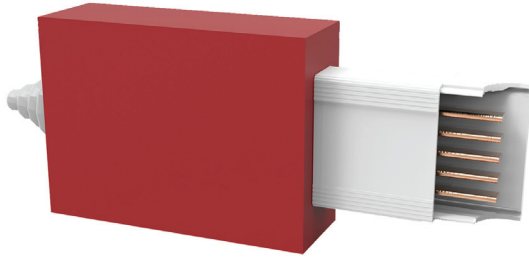

X=min.350 mm

FEED UNIT (LEFT) P+N+Pec

عنصر مزود بمسماح خاص PE+N+P3

Feed Unit (Left) (Cu+Al)

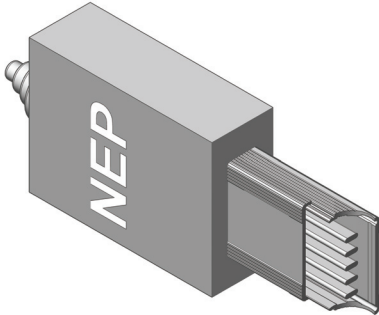

Rated (A) مقدرة (أمبير)	Length (mm) الطول (مم)	Order No رقم الطلب	Pcs. القطع	Weight (Kg) الوزن (كغم)
Composite (Cu+Al)				
LOW 40	3000	AS-L-CP 5530400LFU	1 unit	1,50
LOW 63	3000	AS-L-CP 5530630LFU	1 unit	2,00
LOW 100	3000	AS-L-CP 5531000LFU	1 unit	2,10

FEED UNIT (LEFT) 3P+N+Pec

عنصر مزود بمسماح خاص PE+N+P3

Feed Unit (Left) (Cu+Al)

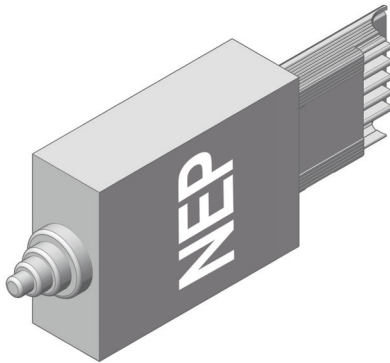

Rated (A) مقدرة (أمبير)	Length (mm) الطول (مم)	Order No رقم الطلب	Pcs. القطع	Weight (Kg) الوزن (كغم)
Composite (Cu+Al)				
LOW 40	3000	AS-L-CP 5550400LFU	1 unit	1,75
LOW 63	3000	AS-L-CP 5550630LFU	1 unit	2,20
LOW 100	3000	AS-L-CP 5551000LFU	1 unit	2,45

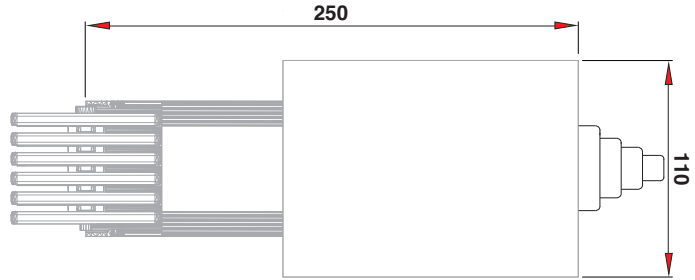
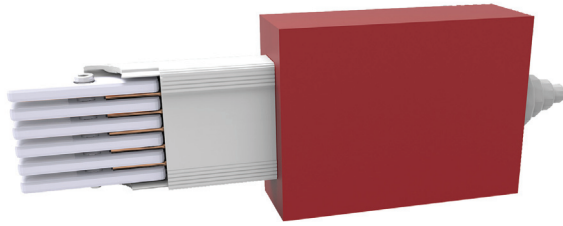

X=min.350 mm

FEED UNIT (RIGHT) P+N+Pec

عنصر مزود بمسمار خاص PE+N+P3

Feed Unit (Right) (Cu+Al)

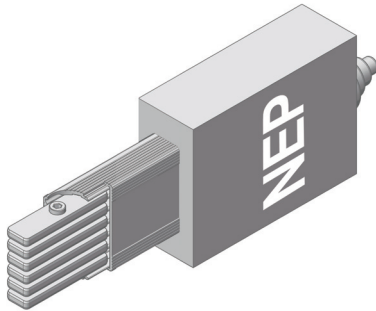

Rated (A) مقدرة (أمبير)	Length (mm) الطول (مم)	Order No رقم الطلب	Pcs. القطع	Weight (Kg) الوزن (كغم)
Composite (Cu+Al)				
LOW 40	3000	AS-L-CP 5530400RFU	1 unit	2,00
LOW 63	3000	AS-L-CP 5530630RFU	1 unit	2,50
LOW 100	3000	AS-L-CP 5531000RFU	1 unit	2,75

FEED UNIT (RIGHT) 3P+N+Pec

عنصر مزود بمسمار خاص PE+N+P3

Feed Unit (Right) (Cu+Al)

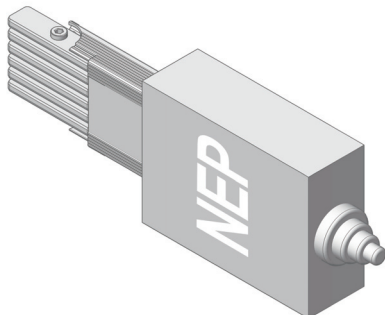

Rated (A) مقدرة (أمبير)	Length (mm) الطول (مم)	Order No رقم الطلب	Pcs. القطع	Weight (Kg) الوزن (كغم)
Composite (Cu+Al)				
LOW 40	3000	AS-L-CP 5550400RFU	1 unit	2,30
LOW 63	3000	AS-L-CP 5550630RFU	1 unit	2,80
LOW 100	3000	AS-L-CP 5551000RFU	1 unit	3,00

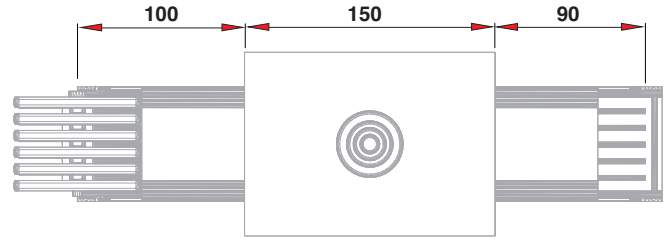
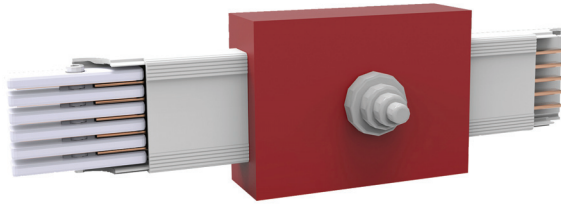

X=min.350 mm

FEED UNIT (CENTER) P+N+Pec

عنصر مزود بمسماار خاص PE+N+P3

Feed Unit (Center) (Cu+Al)

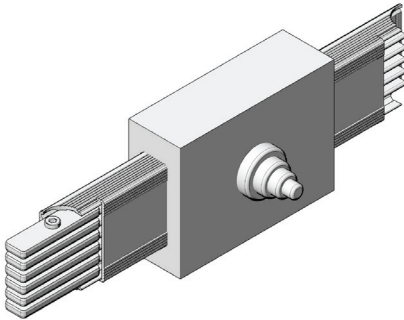

Rated (A) مقدور (أمبير)	Length (mm) الطول (مم)	Order No رقم الطلب	Pcs. القطع	Weight (Kg) الوزن (كغم)
Composite (Cu+Al)				
LOW 40	3000	AS-L-CP 5530400CFU	1 unit	3,00
LOW 63	3000	AS-L-CP 5530630CFU	1 unit	3,80
LOW 100	3000	AS-L-CP 5531000CFU	1 unit	4,00

FEED UNIT (CENTER) 3P+N+Pec

عنصر مزود بمسماار خاص PE+N+P3

Feed Unit (Left) (Cu+Al)

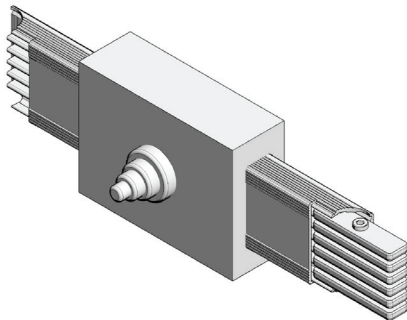

Rated (A) مقدور (أمبير)	Length (mm) الطول (مم)	Order No رقم الطلب	Pcs. القطع	Weight (Kg) الوزن (كغم)
Composite (Cu+Al)				
LOW 40	3000	AS-L-CP 5550400CFU	1 unit	3,60
LOW 63	3000	AS-L-CP 5550630CFU	1 unit	4,00
LOW 100	3000	AS-L-CP 5551000CFU	1 unit	4,20

NEP Compact Busbar Trunking Systems

أنظمة توصيلات قضيب التوزيع المدمجة

Low Power

الطاقة المنخفضة

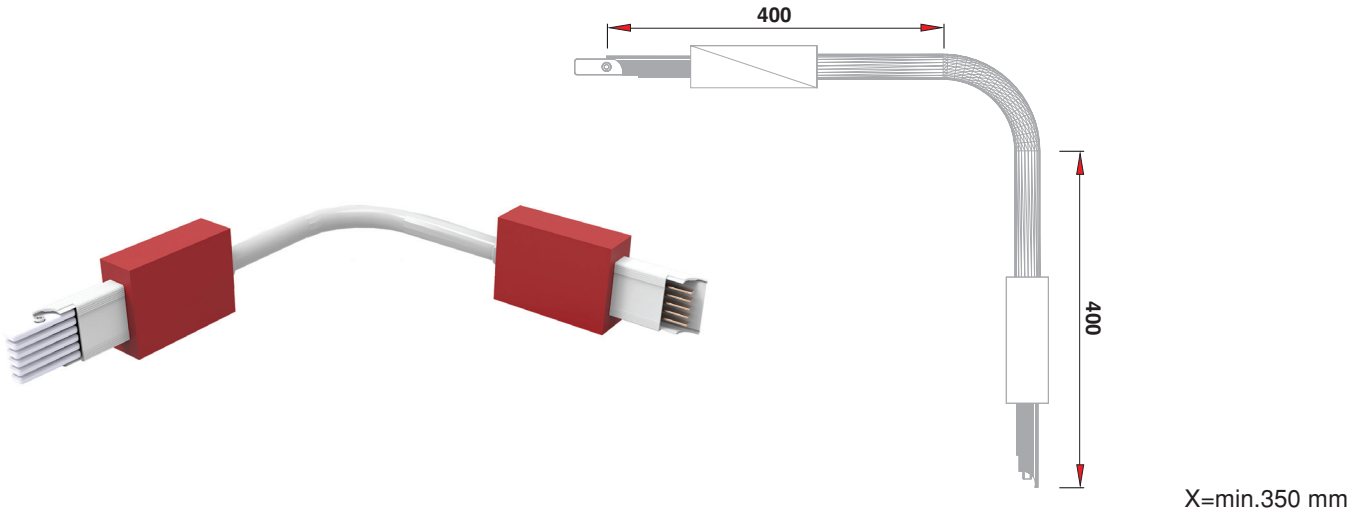

FLEXIBLE JOINT FOR ELBOW P+N+Pec

عنصر مزود بمسمار خاص PE+N+P3

Flexible Joint For Elbow (Cu+Al)

Rated (A) مقدر (أمبير)	Length (mm) الطول (مم)	Order No رقم الطلب	Pcs. القطع	Weight (Kg) الوزن (كغم)
Composite (Cu+Al)				
LOW 40	3000	AS-L-CP 5530400FLX	1 unit	4,50
LOW 63	3000	AS-L-CP 5530630FLX	1 unit	5,00
LOW 100	3000	AS-L-CP 5531000FLX	1 unit	5,20



FLEXIBLE JOINT FOR ELBOW 3P+N+Pec

عنصر مزود بمسمار خاص PE+N+P3

Flexible Joint For Elbow (Cu+Al)

Rated (A) مقدر (أمبير)	Length (mm) الطول (مم)	Order No رقم الطلب	Pcs. القطع	Weight (Kg) الوزن (كغم)
Composite (Cu+Al)				
LOW 40	3000	AS-L-CP 5550400FLX	1 unit	4,80
LOW 63	3000	AS-L-CP 5550630FLX	1 unit	5,30
LOW 100	3000	AS-L-CP 5551000FLX	1 unit	5,50

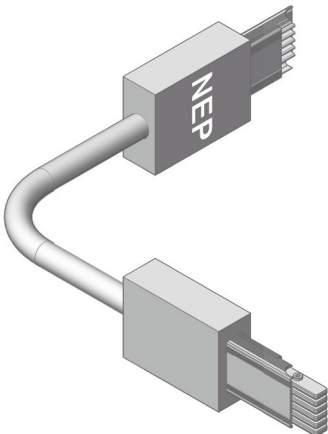

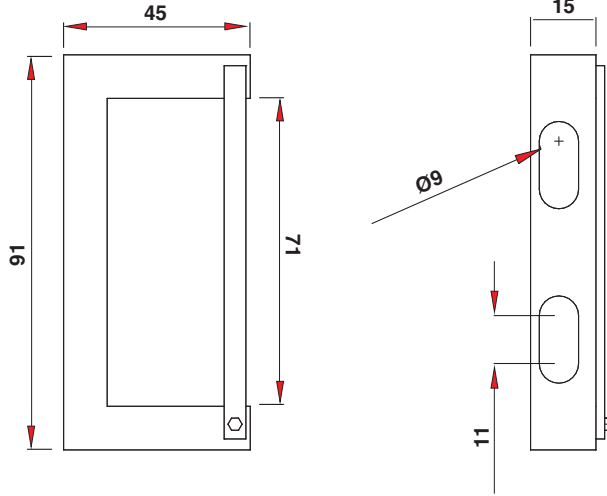
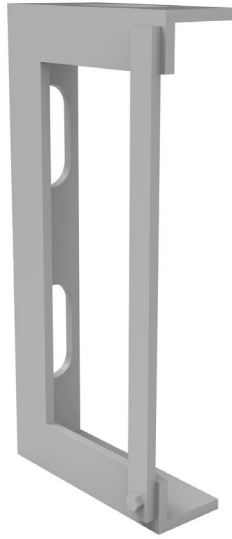

X=min.350 mm

FIXING HANGER FOR BUSBAR

عنصر مزود بمسمار خاص PE+N+P3

Fixing Hanger For Busbar (Cu+Al)

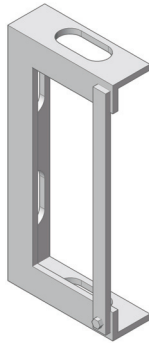

Rated (A) مقدر (أمبير)	Length (mm) الطول (مم)	Order No رقم الطلب	Pcs. القطع	Weight (Kg) الوزن (كغم)
Composite (Cu+Al)				
LOW 40	3000	AS-L-CP 55500401FIX	1 unit	0,33
LOW 63	3000	AS-L-CP 55500631FIX	1 unit	0,33
LOW 100	3000	AS-L-CP 55501001FIX	1 unit	0,33

FIXING HANGER FOR BUSBAR

عنصر مزود بمسمار خاص PE+N+P3

Fixing Hanger For Busbar (Cu+Al)



Rated (A) مقدر (أمبير)	Length (mm) الطول (مم)	Order No رقم الطلب	Pcs. القطع	Weight (Kg) الوزن (كغم)
Composite (Cu+Al)				
LOW 40	3000	AS-L-CP 55500402FIX	1 unit	0,33
LOW 63	3000	AS-L-CP 55500632FIX	1 unit	0,33
LOW 100	3000	AS-L-CP 55501002FIX	1 unit	0,33

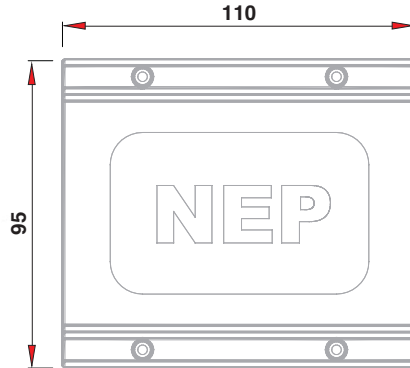
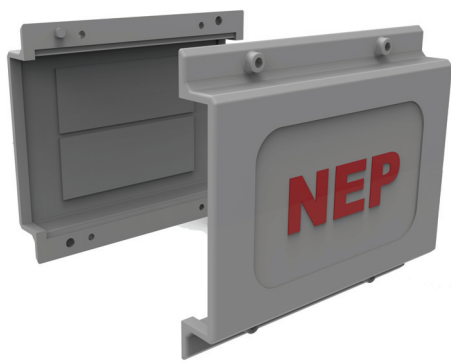

X=min.350 mm

JOINT COVER

عنصر مزود بمسمار خاص PE+N+P3

Joint Cover (Cu+Al)

Rated (A) مقدر (أمبير)	Length (mm) الطول (مم)	Order No رقم الطلب	Pcs. القطع	Weight (Kg) الوزن (كغم)
Composite (Cu+Al)				
LOW 40	3000	AS-L-CP 55500400JCT	1 unit	0,22
LOW 63	3000	AS-L-CP 55500630JCT	1 unit	0,22
LOW 100	3000	AS-L-CP 55501000JCT	1 unit	0,22

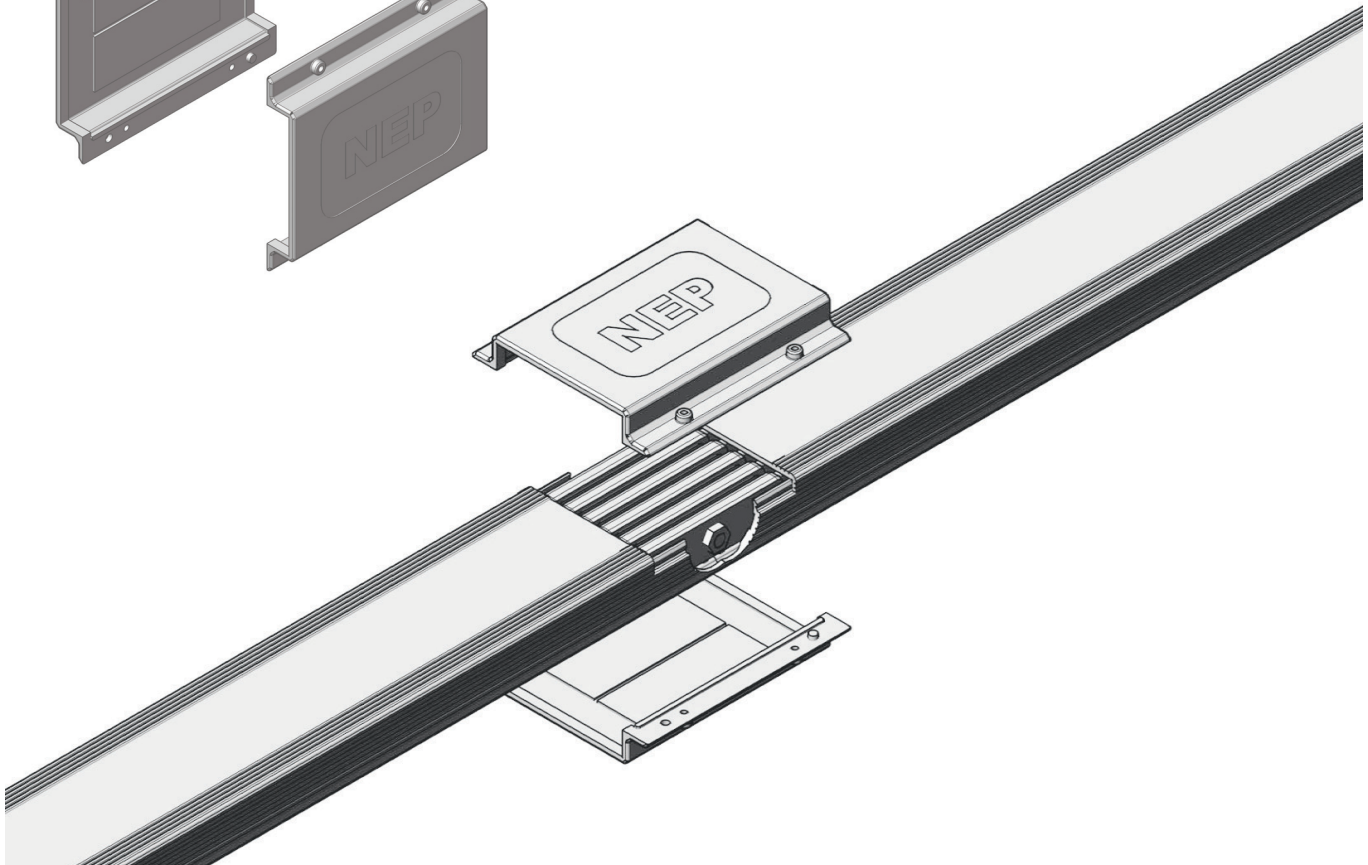
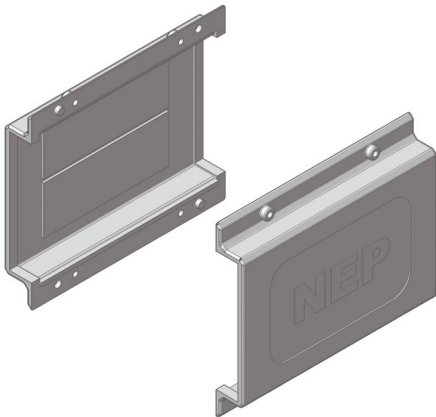

NEP Compact Busbar Trunking Systems

أنظمة توصيلات قضيب التوزيع المدمجة

Low Power

الطاقة المنخفضة

DEKRA KEMA

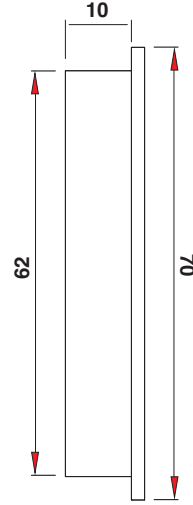

X=min.350 mm

END CAP (LEFT)

عنصر مزود بمسمار خاص PE+N+P3

End Cap (Cu+Al)



Rated (A) مقدر (أمبير)	Length (mm) الطول (مم)	Order No رقم الطلب	Pcs. القطع	Weight (Kg) الوزن (كغم)
Composite (Cu+Al)				
LOW 40	3000	AS-L-CP 55500400ECL	1 unit	0,05
LOW 63	3000	AS-L-CP 55500630ECL	1 unit	0,05
LOW 100	3000	AS-L-CP 55501000ECL	1 unit	0,05

END CAP (LEFT)

عنصر مزود بمسمار خاص PE+N+P3

End Cap (Cu+Al)



Rated (A) مقدر (أمبير)	Length (mm) الطول (مم)	Order No رقم الطلب	Pcs. القطع	Weight (Kg) الوزن (كغم)
Composite (Cu+Al)				
LOW 40	3000	AS-L-CP 55500400ECR	1 unit	0,05
LOW 63	3000	AS-L-CP 55500630ECR	1 unit	0,05
LOW 100	3000	AS-L-CP 55501000ECR	1 unit	0,05

NEP Compact Busbar Trunking Systems

أنظمة توصيلات قضيب التوزيع المدمجة

Low Power

الطاقة المنخفضة

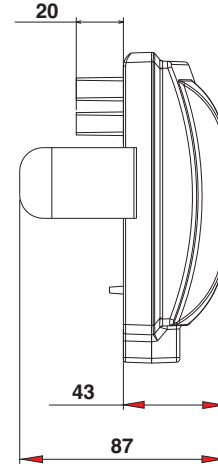
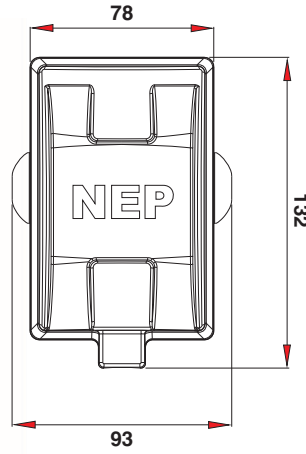

X=min.350 mm

LIGHTING FIXTURE JACK P+N+Pec

عنصر مزود بمسمار خاص PE+N+P3

Lighting Fixture Jack (Cu+Al)



Rated (A) مقدراً (أمبير)	Length (mm) الطول (مم)	Order No رقم الطلب	Pcs. القطع	Weight (Kg) الوزن (كغم)
Composite (Cu+Al)				
LOW 40	3000	AS-L-CP 55310016L1	1 unit	0,15
LOW 63	3000	AS-L-CP 55310016L2	1 unit	0,15
LOW 100	3000	AS-L-CP 55310016L3	1 unit	0,15

LIGHTING FIXTURE JACK P+N+Pec

عنصر مزود بمسمار خاص PE+N+P3

Lighting Fixture Jack (Cu+Al)



Rated (A) مقدراً (أمبير)	Length (mm) الطول (مم)	Order No رقم الطلب	Pcs. القطع	Weight (Kg) الوزن (كغم)
Composite (Cu+Al)				
LOW 40	3000	AS-L-CP 55510016L4	1 unit	0,20

NEP Compact Busbar Trunking Systems

أنظمة توصيلات قضيب التوزيع المدمجة

Low Power

الطاقة المنخفضة

DEKRA KEMA

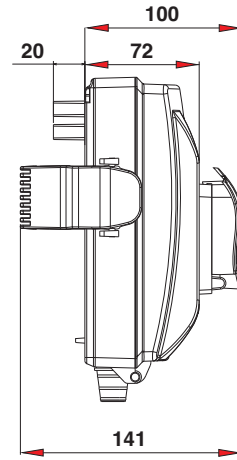
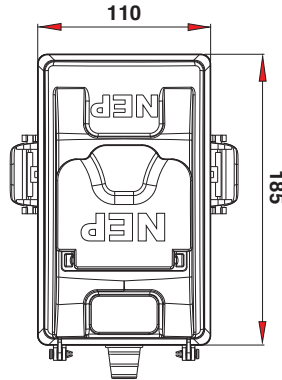
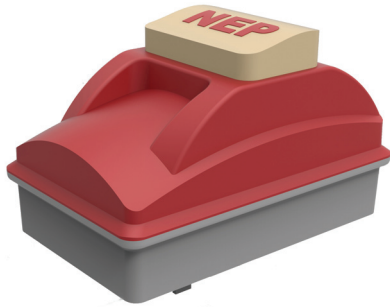

X=min.350 mm

LIGHTING FIXTURE JACK P+N+Pec

عنصر مزود بمسمار خاص PE+N+P3

Lighting Fixture Jack (Cu+Al)

Rated (A) مقدور (أمبير)	Length (mm) الطول (مم)	Order No رقم الطلب	Pcs. القطع	Weight (Kg) الوزن (كغم)
Composite (Cu+Al)				
LOW 40	3000	AS-L-CP 553MDA16L1	1 unit	0,15
LOW 63	3000	AS-L-CP 553MDA16L2	1 unit	0,15
LOW 100	3000	AS-L-CP 553MDA16L3	1 unit	0,15



LIGHTING FIXTURE JACK P+N+Pec

عنصر مزود بمسمار خاص PE+N+P3

Lighting Fixture Jack (Cu+Al)

Rated (A) مقدور (أمبير)	Length (mm) الطول (مم)	Order No رقم الطلب	Pcs. القطع	Weight (Kg) الوزن (كغم)
Composite (Cu+Al)				
LOW 40	3000	AS-L-CP 555MDA16L4	1 unit	0,66

