

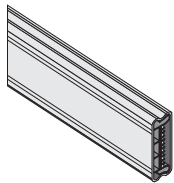

# NAXSOLUX



**Aluminium housing (design by "Giugiaro")**

*Gehäuse Aluminium (Design von « Giugiaro »)*

*Canale prefabbricato in alluminio estruso design "Giugiaro"*

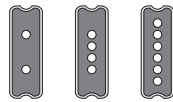

**Two - four - six pole versions with tap-offs on one side**

*Zwei - vier - sechs Pol Ausführung mit*

*Due - quattro - sei poli derivabili su un solo lato*

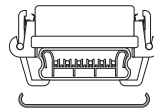

**Retaining spring on all tap-offs**

*Sicherungsklammer An allen Abgangssteckern*

*Molla di sicurezza per tutte le spine*

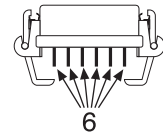

**Six pole tap-off**

*6 - pol Abgangsstecker*

*Spine a sei poli cablabili*

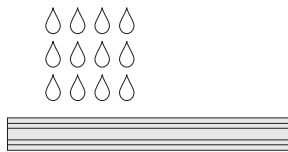

**Degree of protection up to IP55**

*Schutzart bis IP55*

*Eccezionale resistenza alla prova della nebbia salina*

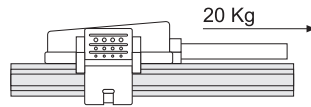

**IMQ certification of load bearing tap-off cable**

*IMQ Zertifikat für mechanische Beanspruchung*

*Certificazione di sicurezza IMQ sullo strappo spina - cavo*

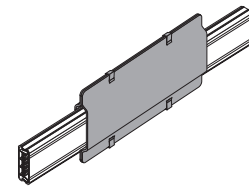

**Where fixings are widely spaced a reinforcement bracket is available For anodised lengths a 20 year guarantee is provided**

*Verstärkungsmanschette fuer lange Abspannweiten Verzinkte Ausführung mit 20 Jahre Garantie*

*Giunzione di rinforzo per irrobustire il sistema in caso di distanza elevata tra gli staffaggi A richiesta, prodotto anodizzato con 20 anni di garanzia*

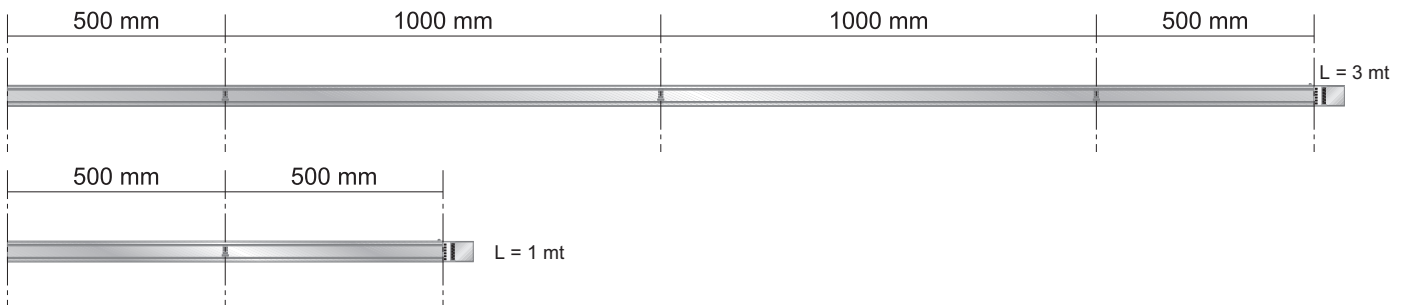

**\*IP55 WITH ACCESSORIES, FROM PAG. 4 / MIT ZUBEHÖR MIT ZUBEHÖR, VON SEITE 4 / CON ACCESSORI, DA PAG. 4**

EN 60439-1-2

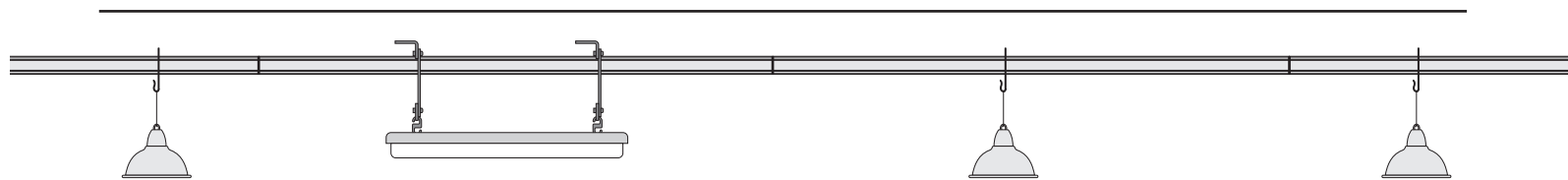

**BRACKET'S SUGGESTION / TIPP BRACKETS / SUGGERIMENTO STAFFE**

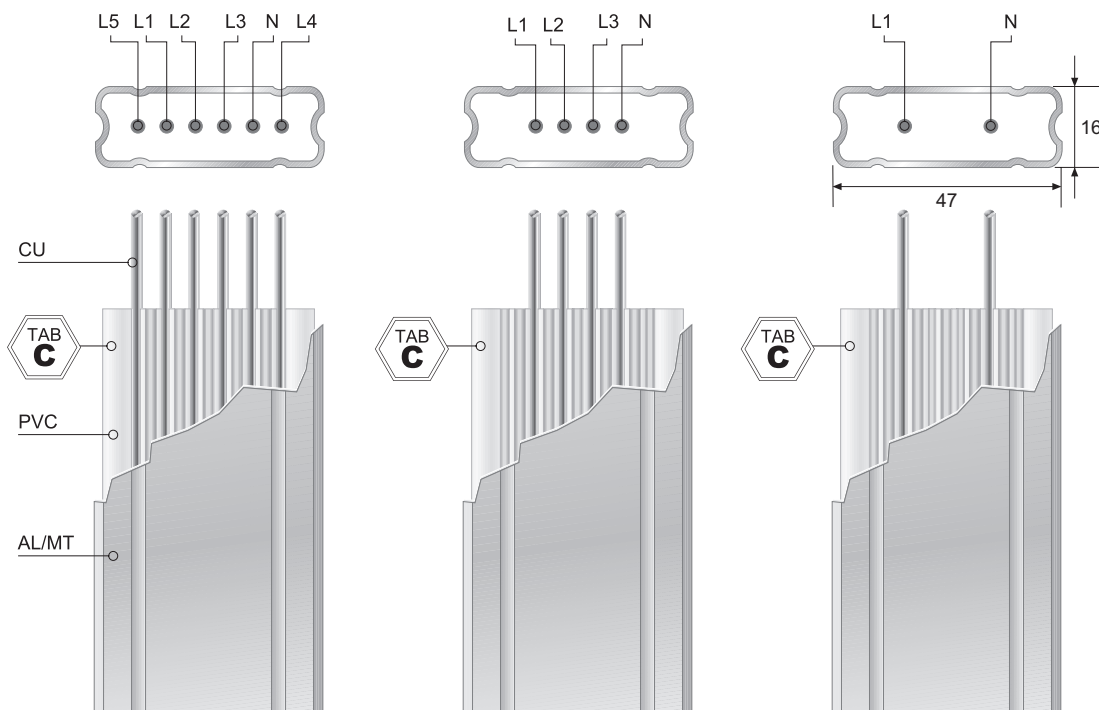

Cod. <b>AL</b>	Kg	L/mm	AMP	Vol. Dm <sup>3</sup>	
BA25A302	1,85	3.000	25	3	
BA25A30	1,95	3.000	25	3	
		3.000	25	3	
BA25A306	2,01	3.000	25	3	
		1.000	25	3	
BA25A3065S	2,01	3.000	25	3	
BA25A106	0,70	1.000	25	1	
BA25A10	0,70	1.000	25	1	
BA40A30	2,20	3.000	40	3	
BA40A306	2,40	3.000	40	3	
BA40A3065S	2,40	3.000	40	3	
BA40A106	0,90	1.000	40	1	
BA63A30	2,40	3.000	63	3	
BA63A10	0,90	1.000	63	1	

**AL** = ALUMINIUM  
ALUMINIUM  
ALLUMINIO

**ATSX 25A**



3P+N+PE

**AMP 25A**

**IP 41 - \*IP 55**

0,22

min. 2,5 mm<sup>2</sup>  
max. 6 mm<sup>2</sup>

0,57 Dm<sup>3</sup>

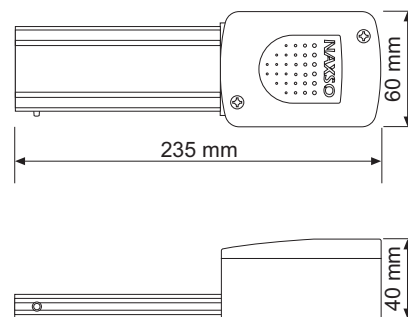

**ATDX 25A**



3P+N+PE

**AMP 25A**

**IP 41 - \*IP 55**

0,4

min. 2,5 mm<sup>2</sup>  
max. 6 mm<sup>2</sup>

0,82 Dm<sup>3</sup>

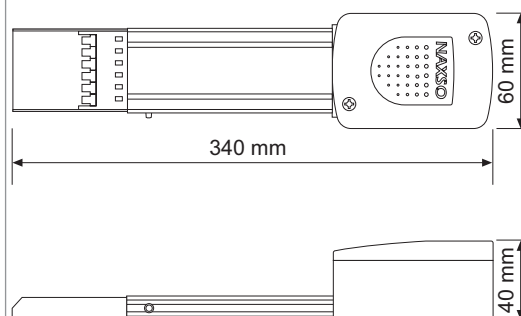

**ATSX 25A6**

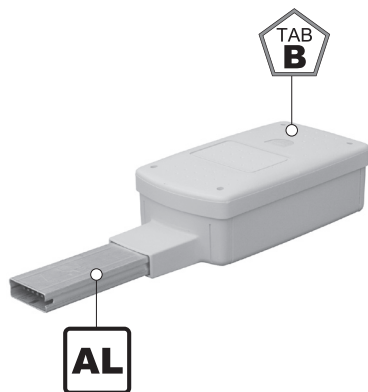

5P+N+PE

**AMP 25A**

**IP 41 - \*IP 55**

0,70

min. 2,5 mm<sup>2</sup>  
max. 6 mm<sup>2</sup>

3,20 Dm<sup>3</sup>

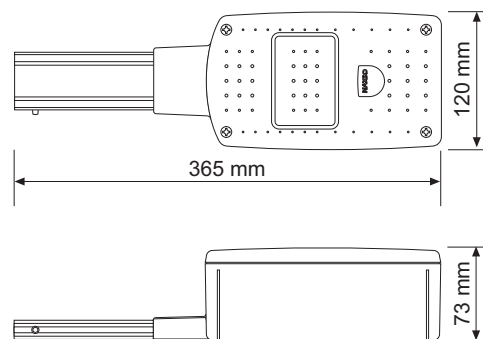

**ATDX 25A6**

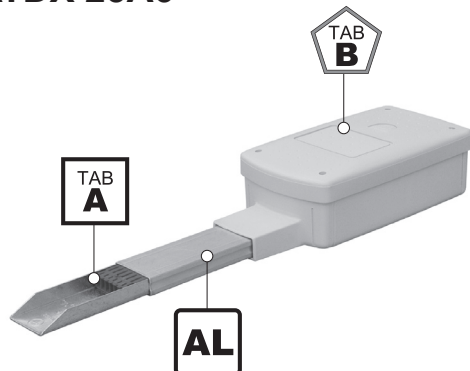

5P+N+PE

**AMP 25A**

**IP 41 - \*IP 55**

0,90

min. 2,5 mm<sup>2</sup>  
max. 6 mm<sup>2</sup>

4,1 Dm<sup>3</sup>

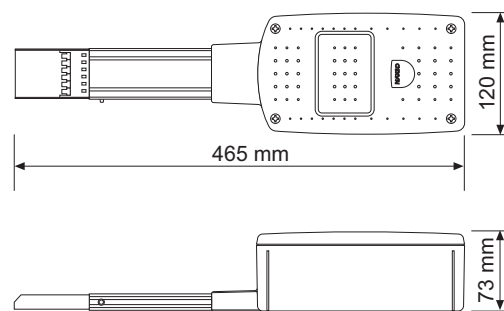

EN 60439-1-2

**ATSX 40A6**

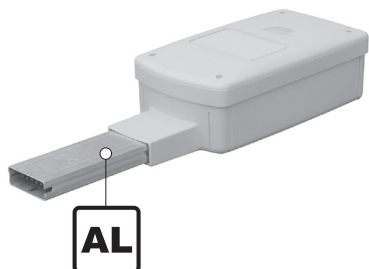

5P+N+PE

**AMP 40A**

**IP 41 - \*IP 55**

0,7

min. 2,5 mm<sup>2</sup>  
max. 10 mm<sup>2</sup>

3,20 Dm<sup>3</sup>

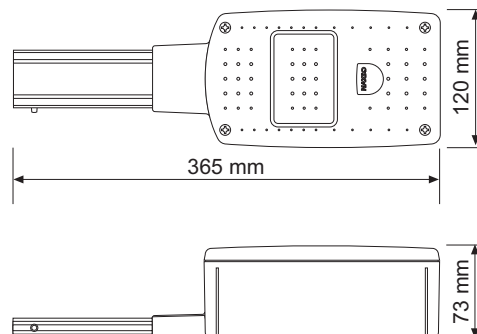

**ATDX 40A6**

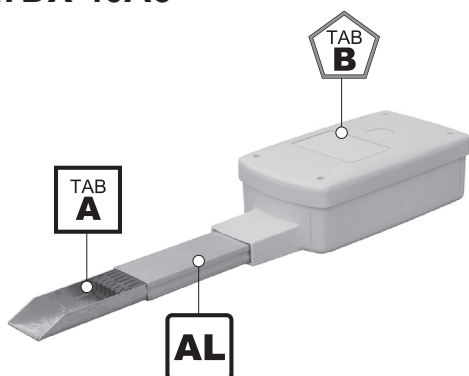

5P+N+PE

**AMP 40A**

**IP 41 - \*IP 55**

0,90

min. 2,5 mm<sup>2</sup>  
max. 10 mm<sup>2</sup>

4,10 Dm<sup>3</sup>

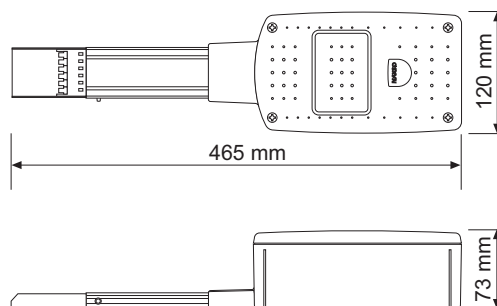

**ATSX 63A**

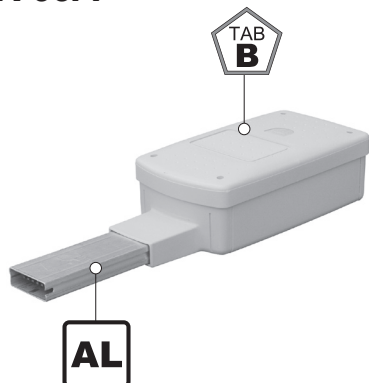

3P+N+PE

**AMP 63A**

**IP 41 - \*IP 55**

0,85

min. 2,5 mm<sup>2</sup>  
max. 16 mm<sup>2</sup>

3,20 Dm<sup>3</sup>

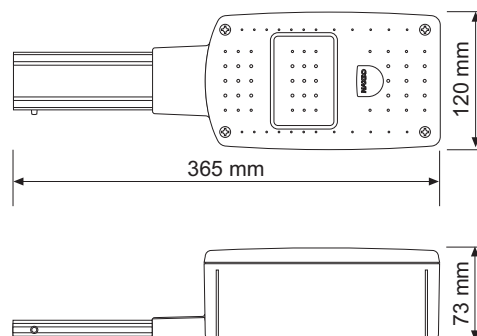

**ATDX 63A**

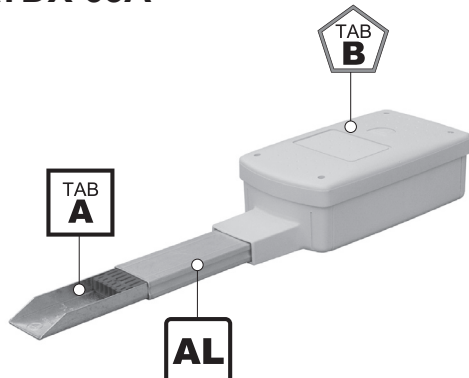

3P+N+PE

**AMP 63A**

**IP 41 - \*IP 55**

1,05

min. 2,5 mm<sup>2</sup>  
max. 16 mm<sup>2</sup>

4,10 Dm<sup>3</sup>

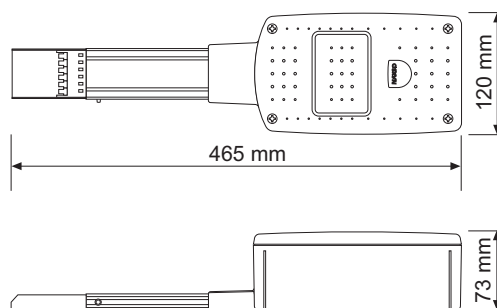

**AC 25A**

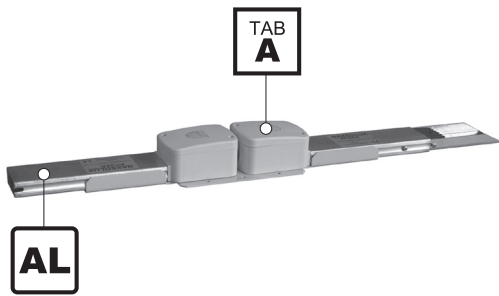

3P+N+PE  
**AMP 25A**  
**IP 41 - \*IP 55**  
 0,89  
 min. 2,5 mm<sup>2</sup>  
 max. 6 mm<sup>2</sup>  
 2,10 Dm<sup>3</sup>

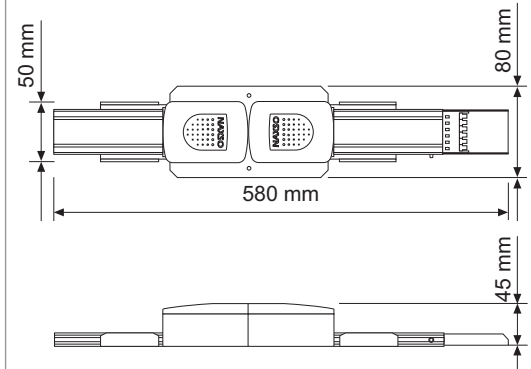

**AC 40AG**

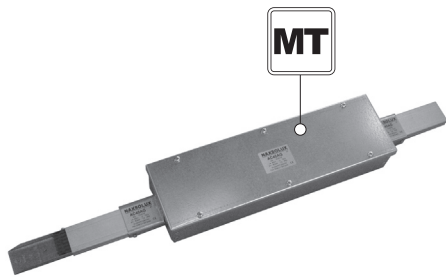

5P+N+PE  
**AMP 40A**  
**IP 41 - \*IP 55**  
 3,6  
 min. 2,5 mm<sup>2</sup>  
 max. 6 mm<sup>2</sup>  
 7,70 Dm<sup>3</sup>

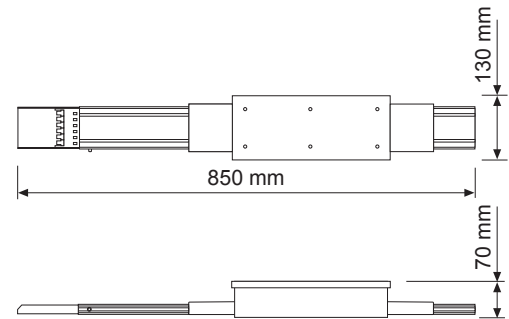

**AC 40A**

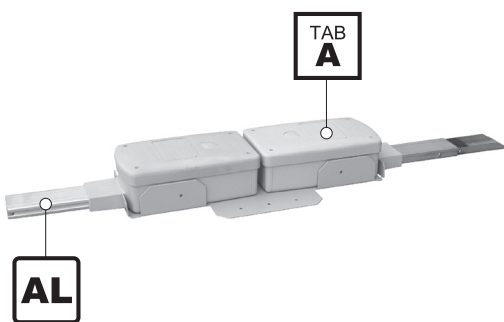

5P+N+T  
**AMP 40A**  
**IP 41 - \*IP 55**  
 2,5  
 min. 2,5 mm<sup>2</sup>  
 max. 10 mm<sup>2</sup>  
 7,70 Dm<sup>3</sup>

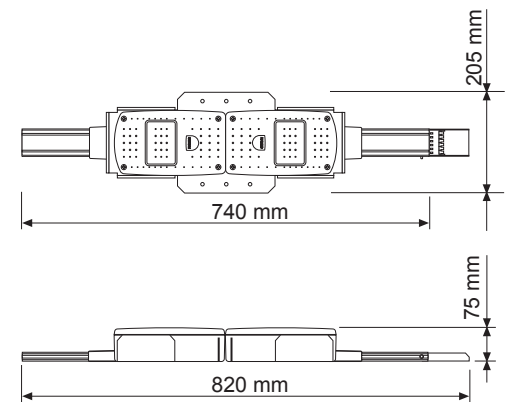

**AC 25A6**

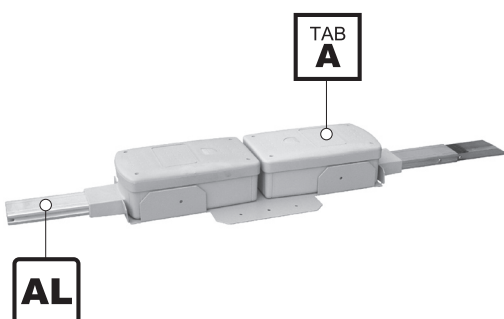

5P+N+PE  
**AMP 25A**  
**IP 41 - \*IP 55**  
 2,5  
 min. 2,5 mm<sup>2</sup>  
 max. 10 mm<sup>2</sup>  
 7,70 Dm<sup>3</sup>

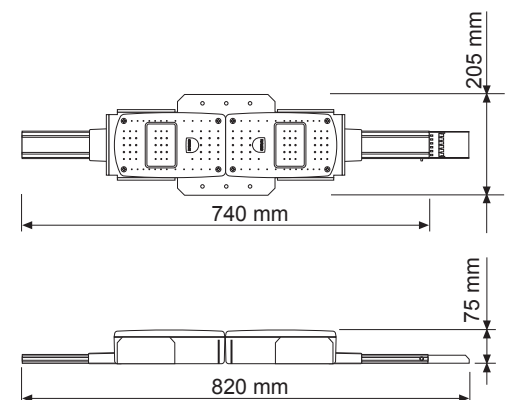

**GFX 40A6**

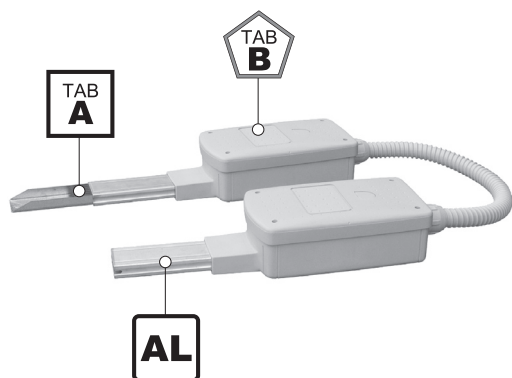

5P+N+PE

**AMP 25 - 40A**

**IP 41 - \*IP 55**

2,05

min. 2,5 mm<sup>2</sup>  
max. 6 mm<sup>2</sup>

26,00 Dm<sup>3</sup>

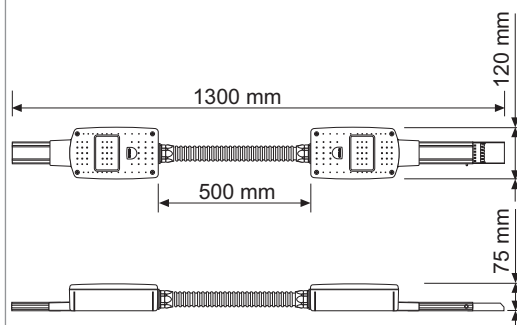

**GFX 25A**

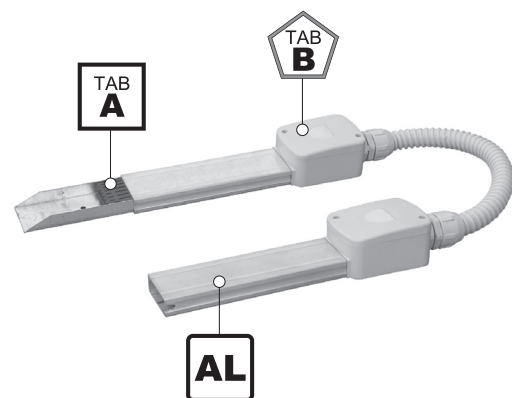

3P+N+PE

**AMP 25A**

**IP 41 - \*IP 55**

0,796

min. 2,5 mm<sup>2</sup>  
max. 6 mm<sup>2</sup>

10,00 Dm<sup>3</sup>

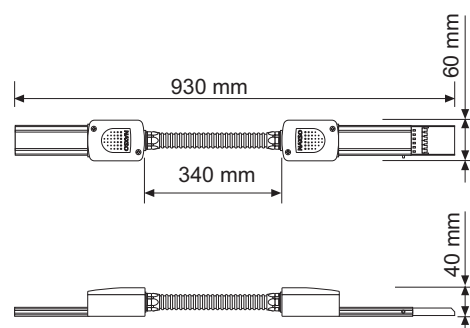

**GFX 25AN**

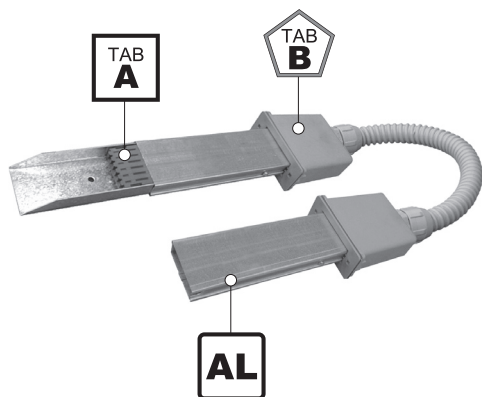

3P+N+PE

**AMP 25A**

**IP 41 - \*IP 55**

0,796

min. 2,5 mm<sup>2</sup>  
max. 6 mm<sup>2</sup>

10,00 Dm<sup>3</sup>

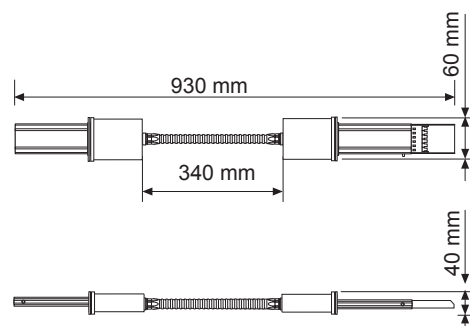

**SM 10A**

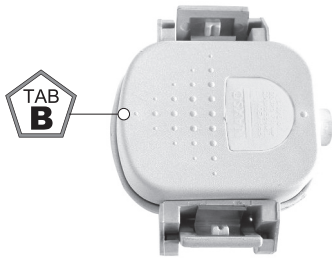

NL+PE

**AMP** 10A

**IP** 41 - \***IP** 55

0,08

max. 2,5 mm<sup>2</sup>

0,23 Dm<sup>3</sup>

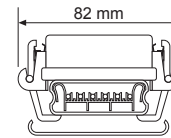
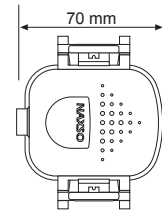

Standard 2 direct contact 10 A

**SM 16A**

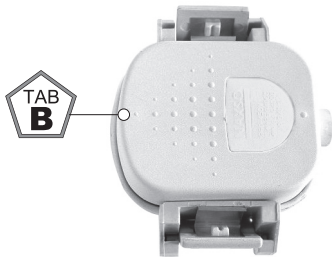

NL+PE

**AMP** 16A

**IP** 41 - \***IP** 55

0,08

max. 2,5 mm<sup>2</sup>

0,23 Dm<sup>3</sup>

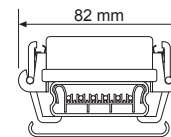
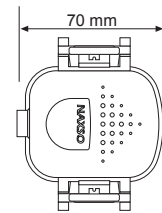

Standard 2 direct contact 16 A

**SM 10ACR**

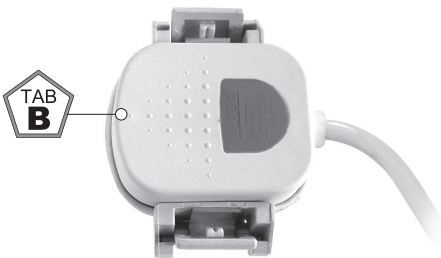

N L1 + PE

**AMP** 10A

**IP** 41 - \***IP** 55

0,15

3x1,5 mm<sup>2</sup>  
L=0,8 mt

0,58 Dm<sup>3</sup>

**L1N = IFSR**

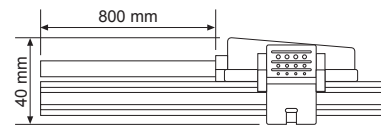
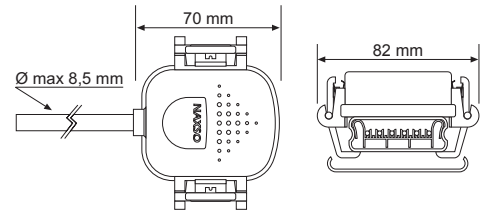

Standard 2 direct contact 10 A

**SM 10ACG**

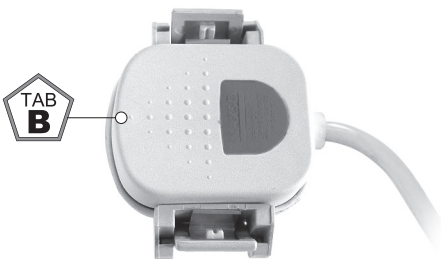

N L2 + PE

**AMP** 10A

**IP** 41 - \***IP** 55

0,15

3x1,5 mm<sup>2</sup>  
L=0,8 mt

0,58 Dm<sup>3</sup>

**L2N = IFSG**

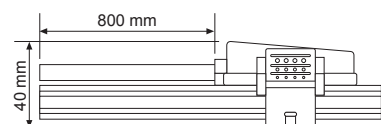
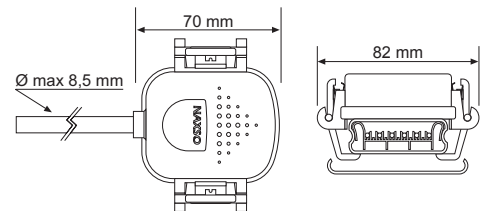

Standard 2 direct contact 10 A

EN 60439-1-2



### SM 10ACB

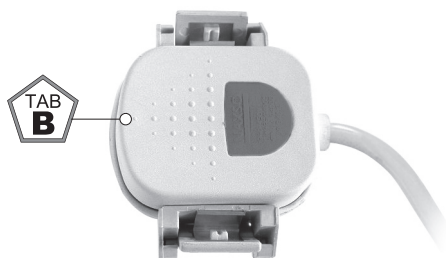

N L3 + PE

**AMP** 10A

**IP** 41 - \***IP** 55

0,15

3x1,5 mm<sup>2</sup>  
L=0,8 mt

0,58 Dm<sup>3</sup>

**L3N** = IFSB

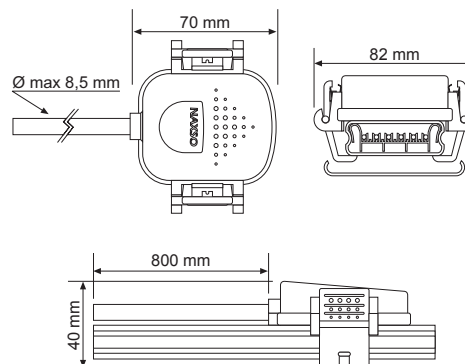

Standard 2 direct contact 10 A

### SM 10ACV

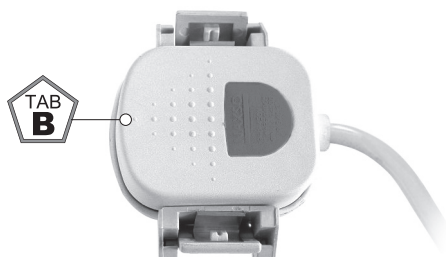

L4 L5 + PE

**AMP** 10A

**IP** 41 - \***IP** 55

0,15

3x1,5 mm<sup>2</sup>  
L=0,8 mt

0,58 Dm<sup>3</sup>

**L4 L5** = IFSV

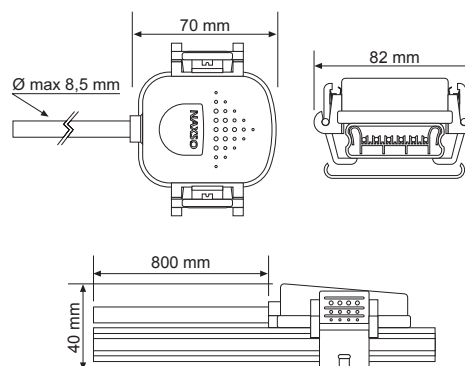

Standard 2 direct contact 10 A

### SFIP 55CR



**AMP** 10A

**IP** 41 - \***IP** 55

0,160

max. 2,5 mm<sup>2</sup>

0,75 Dm<sup>3</sup>

5x20 - 6,3A

3x1,5 mm<sup>2</sup> L=0,8 mt

**L1N** = IFSR

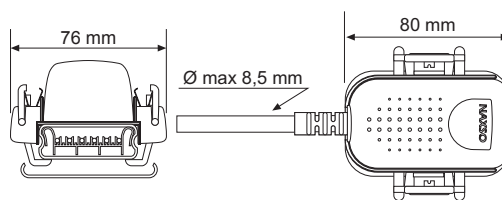
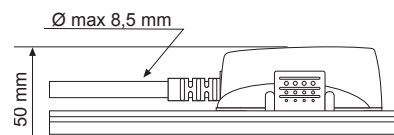

Standard 1 fuse contact + 1 direct contact

### SFIP 55CG



**AMP** 10A

**IP** 41 - \***IP** 55

0,160

max. 2,5 mm<sup>2</sup>

0,75 Dm<sup>3</sup>

5x20 - 6,3A

3x1,5 mm<sup>2</sup> L=0,8 mt

**L2N** = IFSG

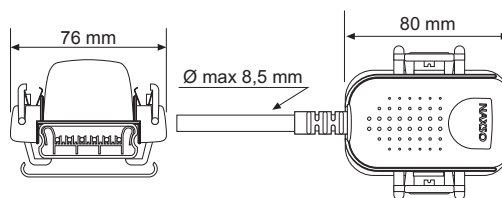
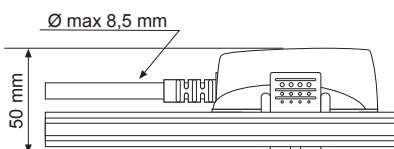

Standard 1 fuse contact + 1 direct contact

EN 60439-1-2

**SFIP 55CB**



Standard 1 fuse contact + 1 direct contact

**AMP 10A**

**IP 41 - \*IP 55**

0,160

max. 2,5 mm<sup>2</sup>

0,75 Dm<sup>3</sup>

5x20 - 6,3A

3x1,5 mm<sup>2</sup> L=0,8 mt

**L3N = IFSB**

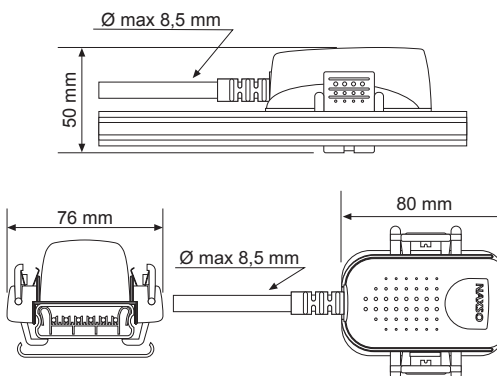

**SFIP**

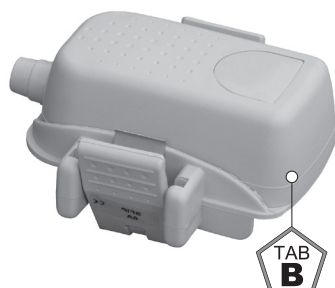

Standard 1 fuse contact + 1 direct contact

1P+N+PE

**AMP 10A**

**IP 41 - \*IP 55**

0,090

max. 2,5 mm<sup>2</sup>

0,3 Dm<sup>3</sup>

5x20 - 6,3A

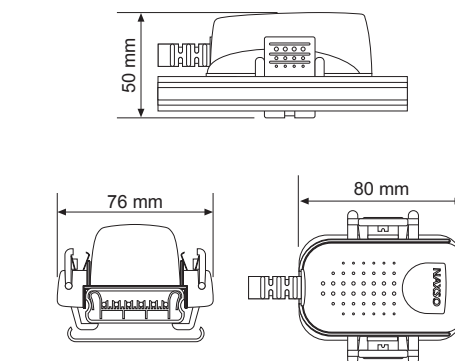

**SBM 6A**



Standard 1 fuse contact + 1 direct contact

1P+N+PE

**AMP 10A**

**IP 41 - \*IP 55**

0,15

max. 2,5 mm<sup>2</sup>

CMSF16 + 1  
 CMCF + 1

0,5 Dm<sup>3</sup>

5x20 - 6,3A

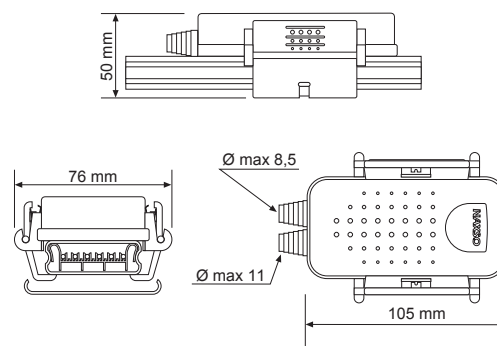

**SBM 16A**



Standard 1 fuse contact + 1 direct contact

1P+N+PE

**AMP 16A**

**IP 41 - \*IP 55**

0,15

max. 2,5 mm<sup>2</sup>

CMSF16 + 1  
 CMCF16 + 1

0,5 Dm<sup>3</sup>

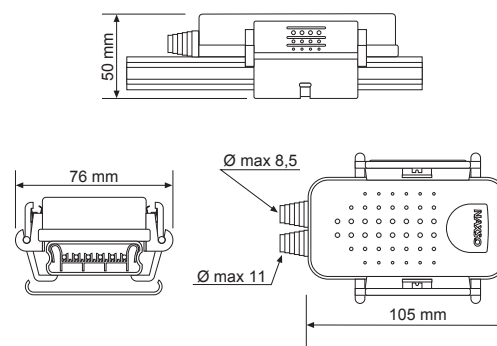

EN 60439-1-2

**CAVO**

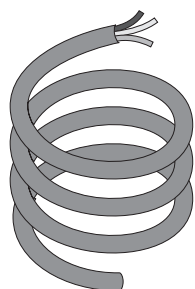

**SFIP**

CPF1508  
CPF1515  
-  
-

**MOUSE**

CPM1508  
CPM1515  
CM2515  
CM2530

**SBM**

CPM1508  
CPM1515  
CM2515  
CM2530

**GRIP55**

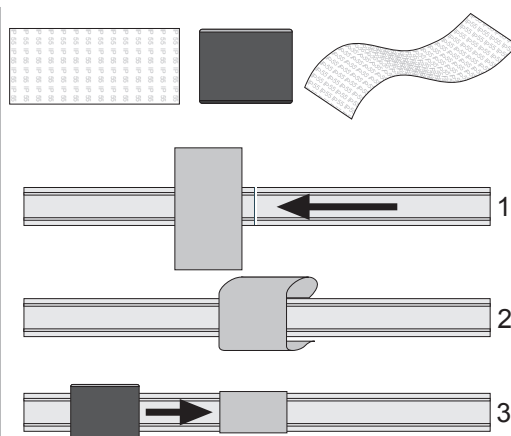
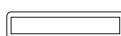
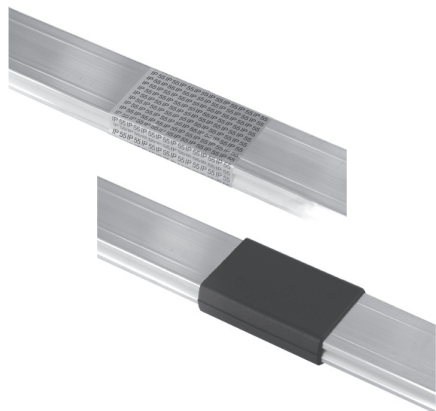

**CTIP55**

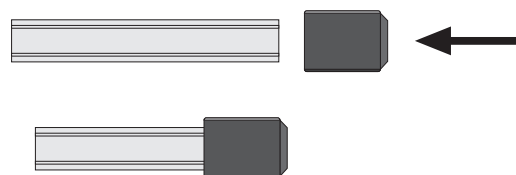
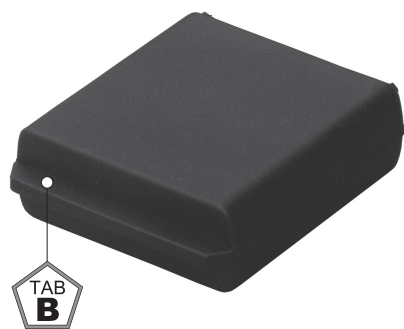

**L1N = IFSR**



**PLASTIC A (TABLE PAG. 88)**  
KUNSTSTOFF-TABELLE A (SEITE 88)  
PLASTICA A (TABELLA PAG. 88)

**L2N = IFSG**



**PLASTIC A (TABLE PAG. 88)**  
KUNSTSTOFF-TABELLE A (SEITE 88)  
PLASTICA A (TABELLA PAG. 88)

**L3N = IFSB**



**PLASTIC A (TABLE PAG. 88)**  
KUNSTSTOFF-TABELLE A (SEITE 88)  
PLASTICA A (TABELLA PAG. 88)

**L4 L5 = IFSV**



**PLASTIC A (TABLE PAG. 88)**  
KUNSTSTOFF-TABELLE A (SEITE 88)  
PLASTICA A (TABELLA PAG. 88)

**CMSFM**



1P

**AMP** 16A

**IP** 55

 max. 2,5 mm<sup>2</sup>

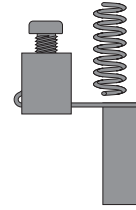

**CMCF16**

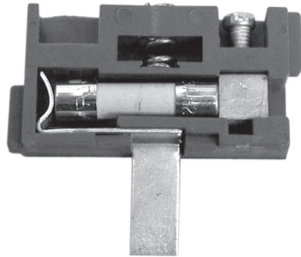

16 A FUSE 5 X 20

**CMSF16**

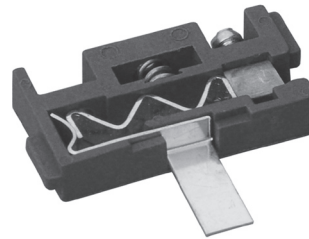

DIRECT CONTACT 16 A

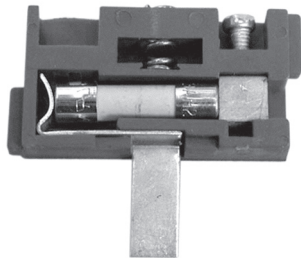

**CMCF**

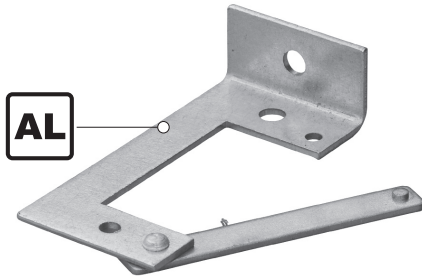

6,3 A FUSE 5 X 20

**STCA**



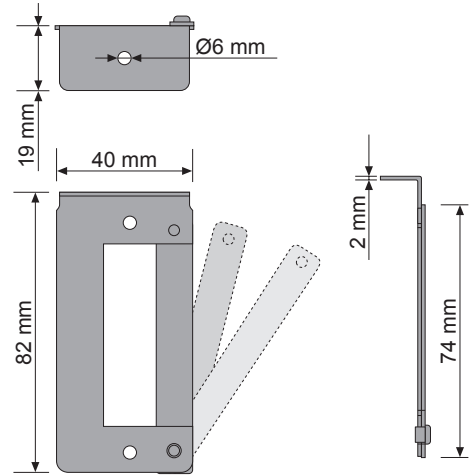

-  0,024
-  max. 10
-  1,000 Dm<sup>3</sup>

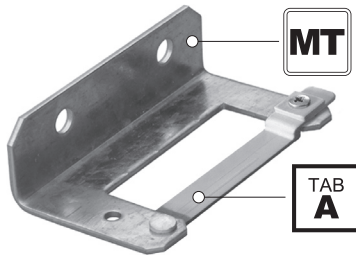

**STCAPV**



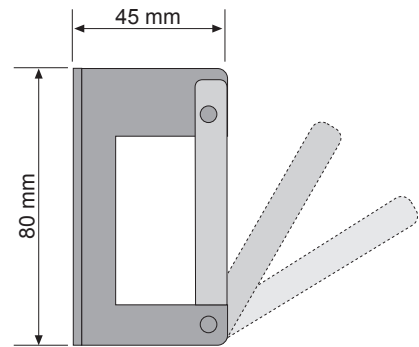

-  0,062
-  max. 30
-  1,000 Dm<sup>3</sup>

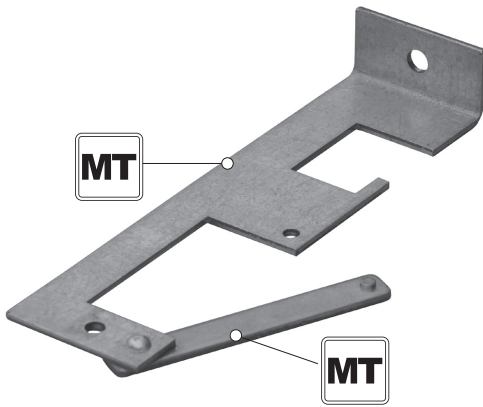

**STCMC**



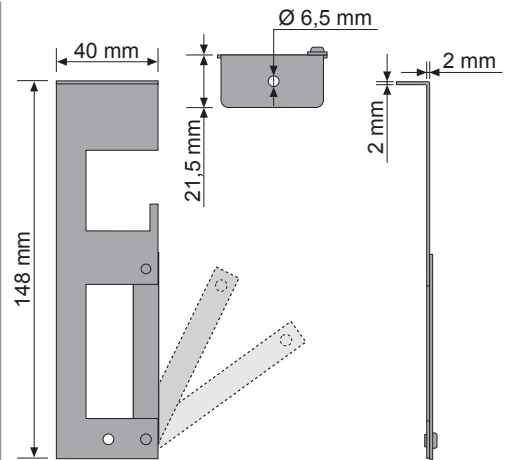

-  0,110
-  max. 30
-  1,000 Dm<sup>3</sup>

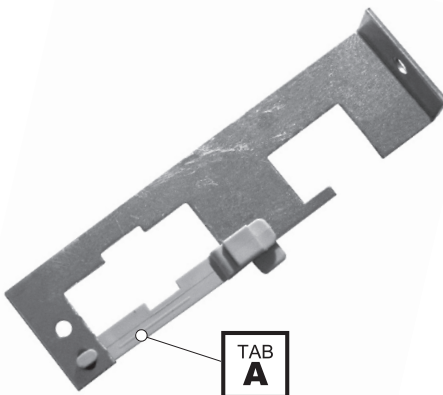

**STCMCP**





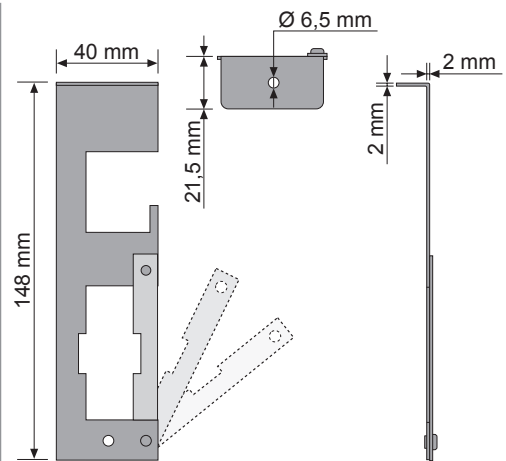

-  0,110
-  max. 30
-  1,000 Dm<sup>3</sup>

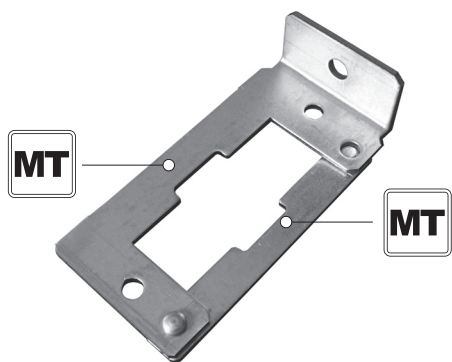

EN 60439-1-2

### STCMM



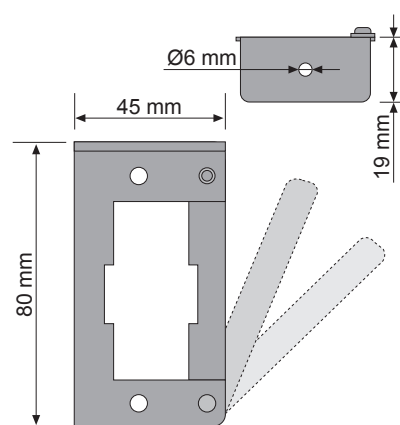

-  0,070
-  max. 30
-  1,000 Dm<sup>3</sup>

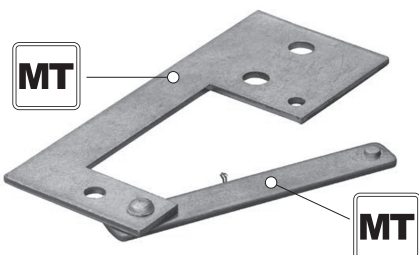

### STCMSF



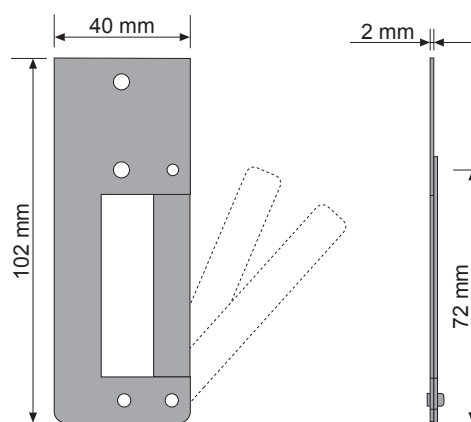

-  0,046
-  max. 30
-  1,000 Dm<sup>3</sup>

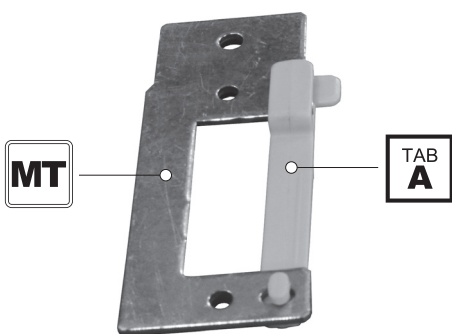

### STCMSP



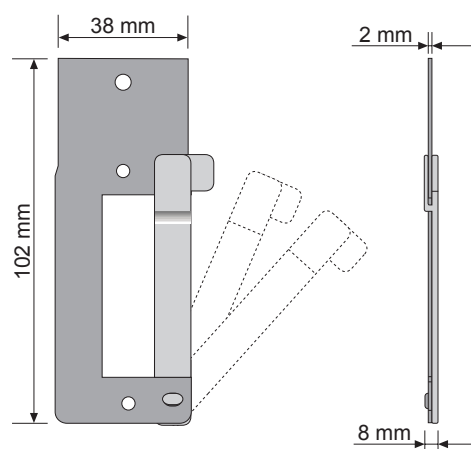

-  0,070
-  max. 30
-  1,000 Dm<sup>3</sup>

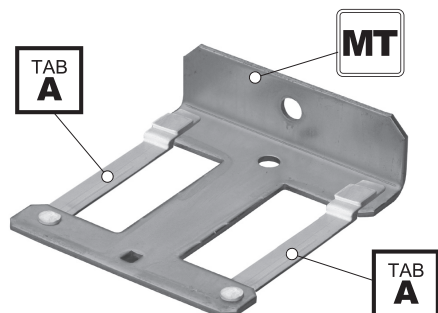

### STCADP





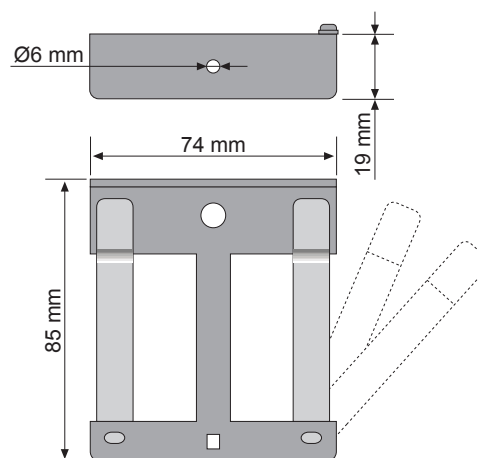

-  0,100
-  max. 30
-  1,000 Dm<sup>3</sup>

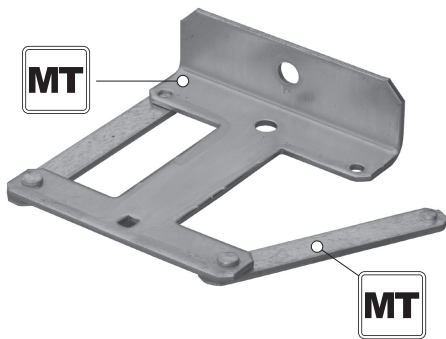

EN 60439-1-2

**STCAD**



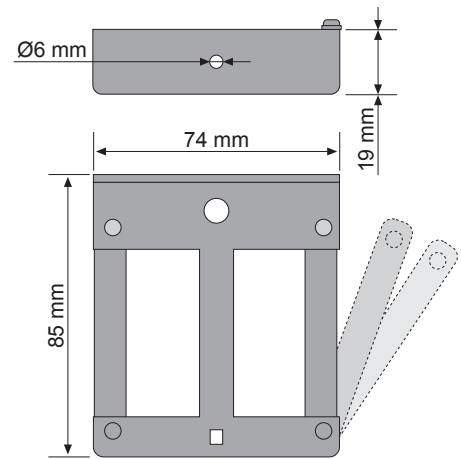

-  0,100
-  max. 30
-  1,000 Dm<sup>3</sup>

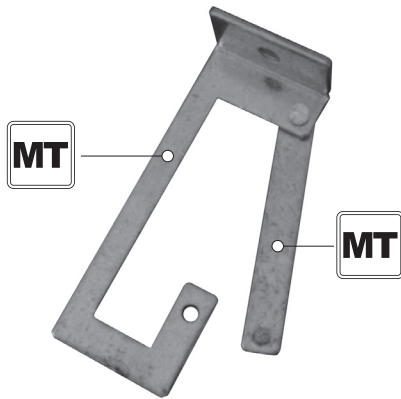

**STCMSA**



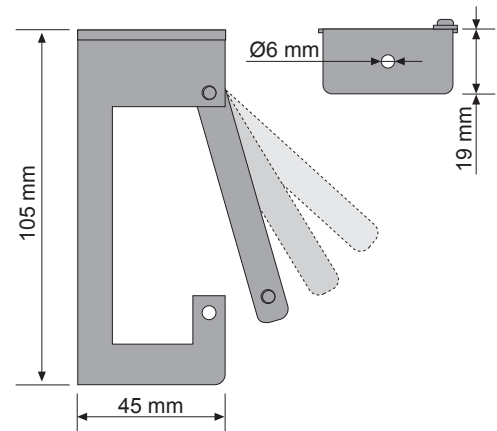

-  0,061
-  max. 30
-  1,000 Dm<sup>3</sup>

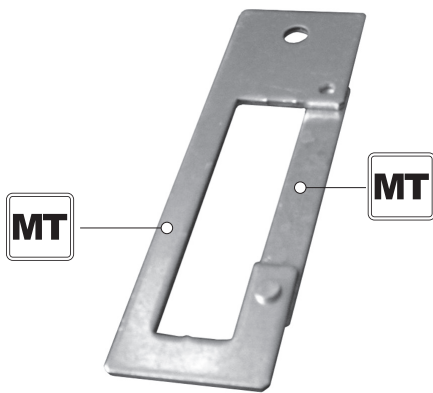

**STCMSD**



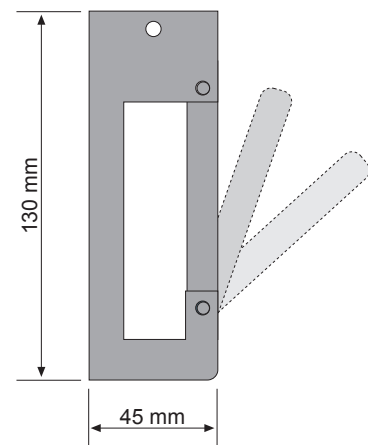

-  0,061
-  max. 30
-  1,000 Dm<sup>3</sup>

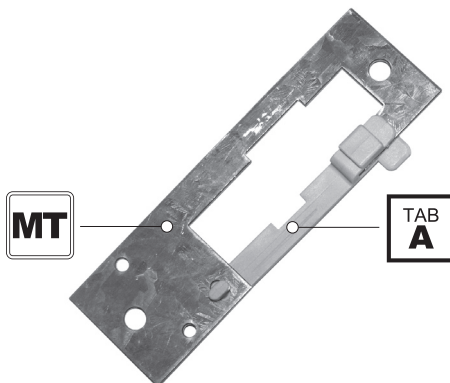

**STCMSDP**



-  0,061
-  max. 30
-  1,000 Dm<sup>3</sup>

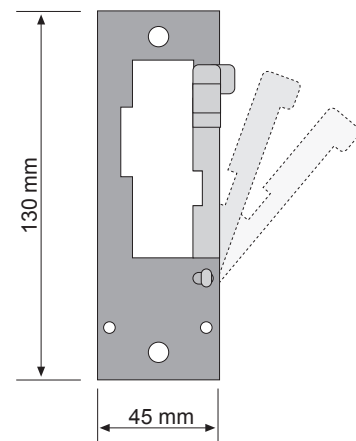



EN 60439-1-2

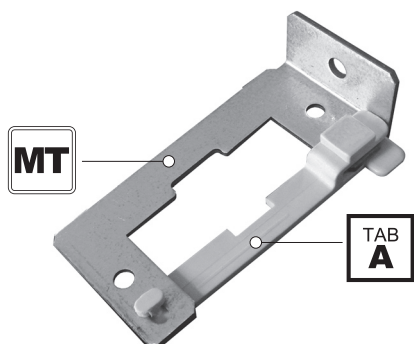

**STCMMP**



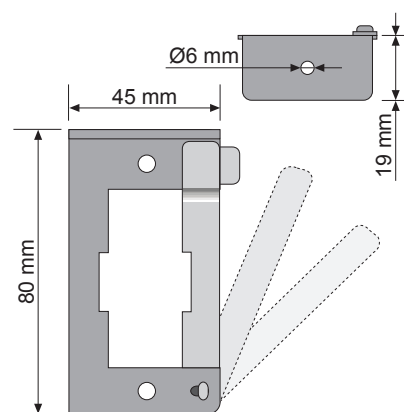

-  0,070
-  max. 30
-  1,000 Dm<sup>3</sup>

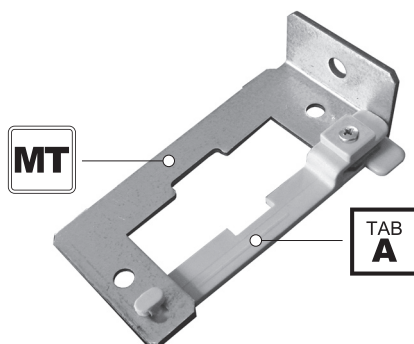

**STCMMPV**



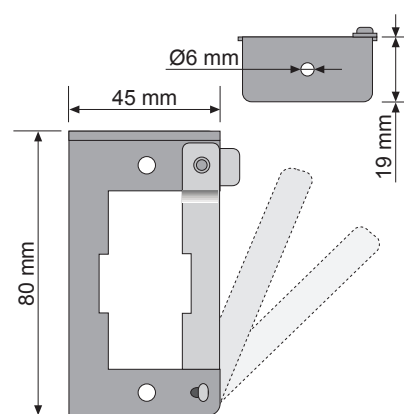

-  0,070
-  max. 30
-  1,000 Dm<sup>3</sup>

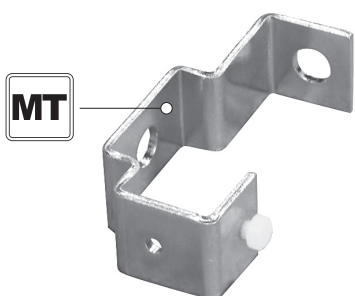

**STM**



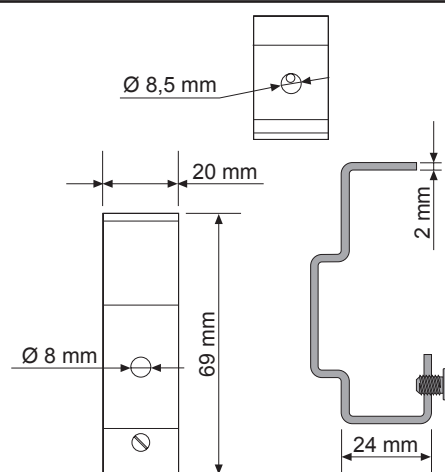

-  0,038
-  max. 30
-  1,000 Dm<sup>3</sup>



**STSF**



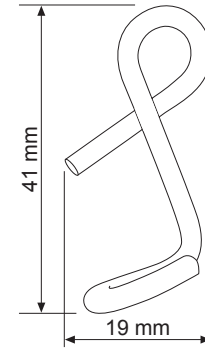

-  0,006
-  max. 20
-  1,000 Dm<sup>3</sup>

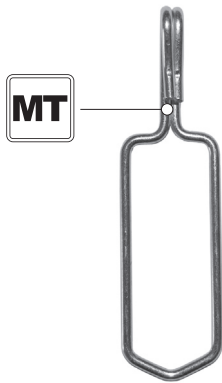

**STCI**



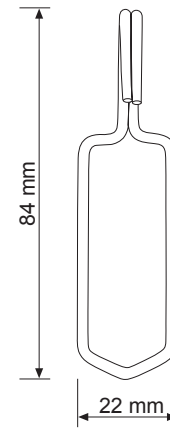

-  0,009
-  max. 12
-  1,000 Dm<sup>3</sup>

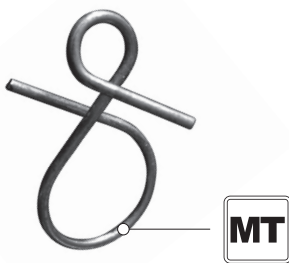

**ST8**



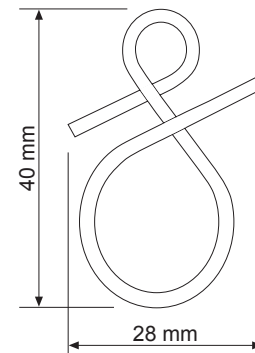

-  0,004
-  max. 12
-  1,000 Dm<sup>3</sup>

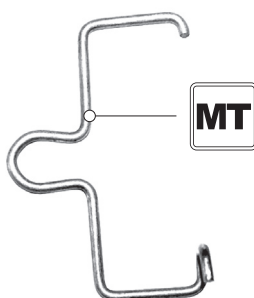

**STSAF**





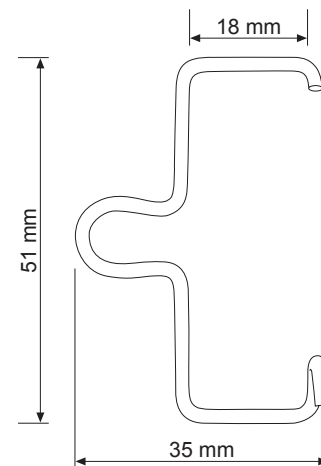

-  0,006
-  max. 12
-  1,000 Dm<sup>3</sup>

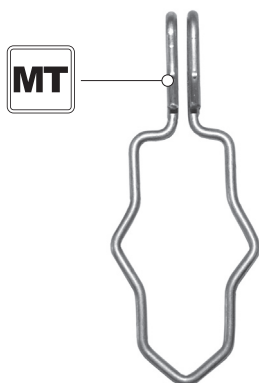

EN 60439-1-2

**STLN**



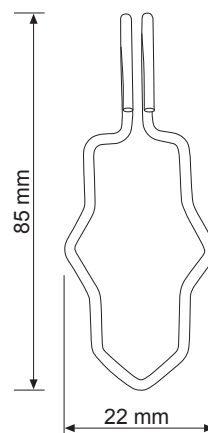

-  0,008
-  max. 20
-  1,000 Dm<sup>3</sup>

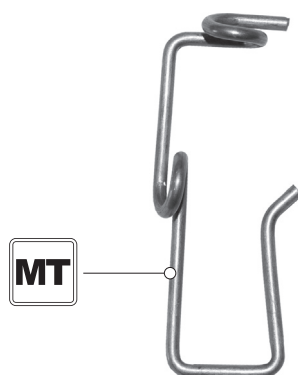

**STMF**



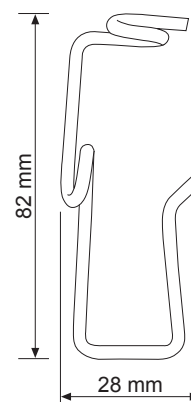

-  0,007
-  max. 12
-  1,000 Dm<sup>3</sup>



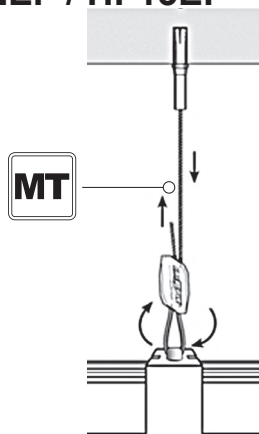

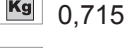
**HF12EF / HF13EF**

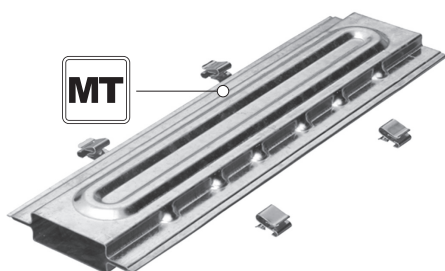

-  0,035
-  0,715
-  max. 30
-  1,000 Dm<sup>3</sup>

**GRFP**



-  0,304
-  1,000 Dm<sup>3</sup>

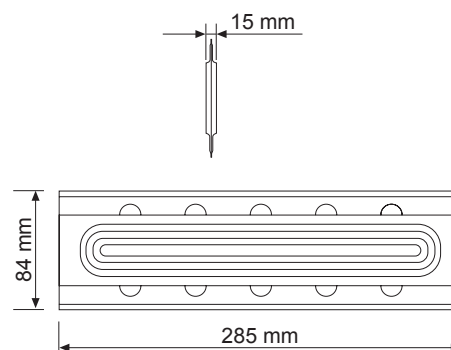

**NAXSOLUX**







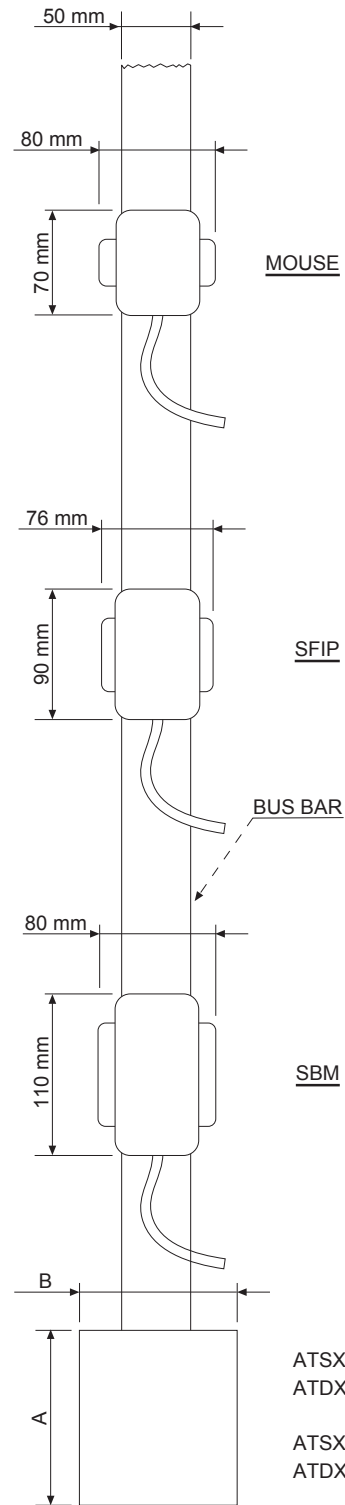
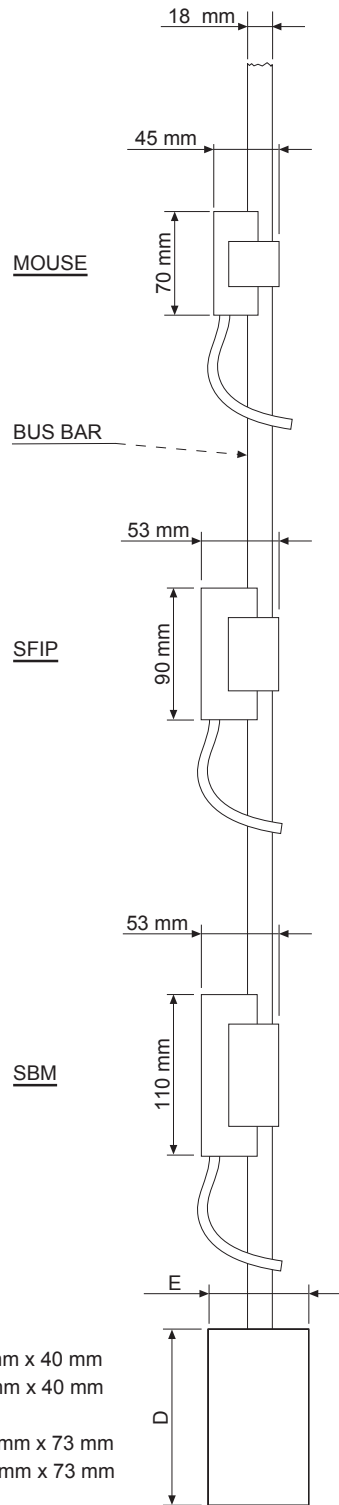

Rated Current	$I_n$ [A]	25	40	63
Dimensions	mm	50 x 18	50 x 18	50 x 18
Rated operational voltage	$U_e$ [V]	400	400	400
Rated insulation voltage	$U_i$ [V]	690	690	690
Frequency	f [Hz]	50/60	50/60	50/60
Rated short time withstand current (1s)	$I_{cw}$ [kA] <sub>RMS</sub>	3	3,3	3,6
Peak Current	$I_{pk}$ [kA]	4,5	5	5,4
Phase live conductor cross section		2,5	6	6
Phase resistance at 20° C	$R_{20}$ [mΩ/m]	6,19	2,96	2,31
Phase reactance (50Hz)	$X_1$ [mΩ/m]	1,3	0,62	0,49
Phase impedance	$Z_1$ [mΩ/m]	8,15	3,9	3,04
Phase resistance at thermal conditions	$R_1$ [mΩ/m]	8,05	3,85	3
Pe resistance	$R_{PE}$ [mΩ/m]	1,32	1,32	1,32
Fault loop resistance phase/N	$R_{FN}$ [mΩ/m]	14,24	6,81	5,31
Fault loop reactance phase/N	$X_{FN}$ [mΩ/m]	1,3	0,62	0,49
Fault loop impedance phase/N	$Z_{FN}$ [mΩ/m]	14,3	6,84	5,34
Fault loop resistance phase/PE	$R_{FPE}$ [mΩ/m]	8,26	4,71	3,99
Fault loop reactance phase/PE	$X_{FPE}$ [mΩ/m]	1,89	1,08	0,91
Fault loop impedance phase/PE	$Z_{FPE}$ [mΩ/m]	8,47	4,83	4,1
Voltage Drop with distributed load	$\Delta V$ [V/m/A] 10-3 $\cos \varphi = 0,70$	5,68	2,72	2,12
	$\Delta V$ [V/m/A] 10-3 $\cos \varphi = 0,75$	5,97	2,86	2,23
	$\Delta V$ [V/m/A] 10-3 $\cos \varphi = 0,80$	6,25	2,99	2,33
	$\Delta V$ [V/m/A] 10-3 $\cos \varphi = 0,85$	6,52	3,12	2,43
	$\Delta V$ [V/m/A] 10-3 $\cos \varphi = 0,90$	6,76	3,23	2,52
	$\Delta V$ [V/m/A] 10-3 $\cos \varphi = 0,95$	5,44	2,6	2,6
	$\Delta V$ [V/m/A] 10-3 $\cos \varphi = 0,100$	6,97	3,33	2,6
Weight	$p$ [kg/m]	0,65	0,7	0,77
Degree of protection	IP	41/55	41/55	41/55
Losses for the joule effect at rated current	P [W/m]	5	6	12
Temperature range		-5°+40°	-5°+40°	-5°+40°
ALL THESE PRODUCTS ARE COMPLIANCE TO STANDARDS IEC 60439 -1 and 2				
ALL THESE PRODUCTS HAVE BEEN CERTIFIED AT IMQ INSTITUTE IN MILAN				







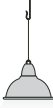

**NAXSOLUX**

Bemessungsstrom	$I_n$ [A]	25	40	63
Abmessungen	mm	50 x 18	50 x 18	50 x 18
Bemessungsbetriebsspannung	$U_e$ [V]	400	400	400
Bemessungsisolationsspannung	$U_i$ [V]	690	690	690
Nennfrequenz	$f$ [Hz]	50/60	50/60	50/60
Bemessungskurzzeitstromfestigkeit (1s)	$I_{cw}$ [kA] <sub>RMS</sub>	3	3,3	3,6
Bemessungsstromstossfestigkeit	$I_{pk}$ [kA]	4,5	5	5,4
Wirkwiderstand bei 20°C	$R_{20}$ [mΩ/m]	6,19	2,96	2,31
Blindwiderstand	$X_l$ [mΩ/m]	1,3	0,62	0,49
Scheinwiderstand Phase	$Z_l$ [mΩ/m]	8,15	3,9	3,04
Wirkwiderstand Phasen bei Enderwärmung der Schienen	$R_r$ [mΩ/m]	8,05	3,85	3
Wirkwiderstand PE-Leiter	$R_{PE}$ [mΩ/m]	1,32	1,32	1,32
Wirkwiderstand im Fehlerfall / N	$R_{FN}$ [mΩ/m]	14,24	6,81	5,31
Blindwiderstand im Fehlerfall / N	$X_{FN}$ [mΩ/m]	1,3	0,62	0,49
Scheinwiderstand im Fehlerfall / N	$Z_{FN}$ [mΩ/m]	14,3	6,84	5,34
Wirkwiderstand im Fehlerfall / PE	$R_{FPE}$ [mΩ/m]	8,26	4,71	3,99
Blindwiderstand im Fehlerfall / PE	$X_{FPE}$ [mΩ/m]	1,89	1,08	0,91
Scheinwiderstand im Fehlerfall / PE	$Z_{FPE}$ [mΩ/m]	8,47	4,83	4,1
Spannungsfall bei gleichmäßig verteilter Last	$\Delta V$ [V/m/A] 10-3 $\cos \varphi = 0,70$	5,68	2,72	2,12
	$\Delta V$ [V/m/A] 10-3 $\cos \varphi = 0,75$	5,97	2,86	2,23
	$\Delta V$ [V/m/A] 10-3 $\cos \varphi = 0,80$	6,25	2,99	2,33
	$\Delta V$ [V/m/A] 10-3 $\cos \varphi = 0,85$	6,52	3,12	2,43
	$\Delta V$ [V/m/A] 10-3 $\cos \varphi = 0,90$	6,76	3,23	2,52
	$\Delta V$ [V/m/A] 10-3 $\cos \varphi = 0,95$	5,44	2,6	2,6
	$\Delta V$ [V/m/A] 10-3 $\cos \varphi = 0,100$	6,97	3,33	2,6
Gewicht	$p$ [kg/m]	0,65	0,7	0,77
Schutzart ohne / mit Zusatzausrüstung IP	IP	41/55	41/55	41/55
Verlustleistung bei Nennstrom P	$P$ [W/m]	5	6	12
Einsatztemperatur Bereich		-5°+40°	-5°+40°	-5°+40°
ALLE PRODUKTE ENTSPRECHEN DER NORM DIN IEC 60439 -1 und 2				
ALLE PRUDUKTE ENTSPRECHEN DEN QUALITÄTSSTANDART IMQ-Milano				

LUX



							
	1 x 250 Jodur	1 x 250 sodium	1 x 150 sodium	1 x 36	1 x 58	2 x 36	2 x 58
25A 1P + N+T	A = 10 B = 8	A = 8 B = 7	A = 20 B = 16	A = 60 B = 50	A = 50 B = 40	A = 40 B = 35	A = 25 B = 20
40A 1P + N+T	A = 20 B = 18	A = 14 B = 12	A = 30 B = 25	A = 90 B = 70	A = 70 B = 60	A = 50	A = 45
							
	1 x 400 Jodur	1 x 400 sodium					
25A 1P + N+T	A = 9 B = 8	A = 6 B = 5					
40A 1P + N+T	A = 16 B = 14	A = 10					

							
	1 x 250 Jodur	1 x 250 sodium	1 x 150 sodium	1 x 36	1 x 58	2 x 36	2 x 58
25A 3P + N+T	A = 24 B = 20	A = 16 B = 14	A = 40 B = 35	A = 150 B = 120	A = 120 B = 100	A = 100 B = 80	A = 60
40A 3P + N+T	40	28	60	200	160	120	110
							
	1 x 400 Jodur	1 x 400 sodium					
25A 3P + N+T	A = 18 B = 16	A = 12 B = 10					
40A 3P + N+T	A = 32 B = 28	A = 20 B = 16					

- 25A MAX 100 MT
- 25A 1P + N + T = 100 % RATING
- 25A 3P + N + T = 100 % RATING
- 40A MAX 140 MT
- 40A 1P + N + T = 100 % RATING
- 40A 3P + N + T = 100 % RATING
- 25A 5P + N + T = 25A 3P + N + T = 100 % RATING + 25A 1P + N + T = 80 % RATING (2 x 25A + 1 X 20A)
- 40A 5P + N + T = 40A 3P + N + T = 100 % RATING + 40A 1P + N + T = 80 % RATING(2 x 40A + 1 X 32A)
- 25A 1P + N + T + 25A 1P + N + T = 90% RATING (2 X 20A)

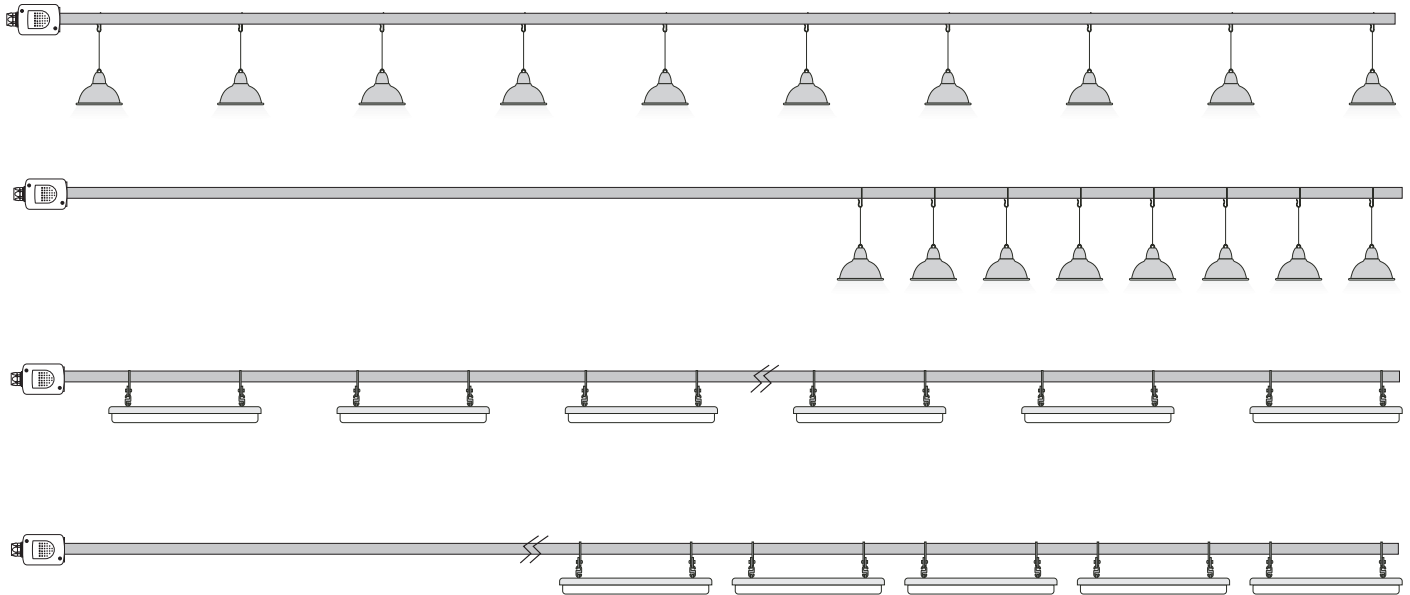

A = 100%    B = 70%    C = 100%    D = 80%

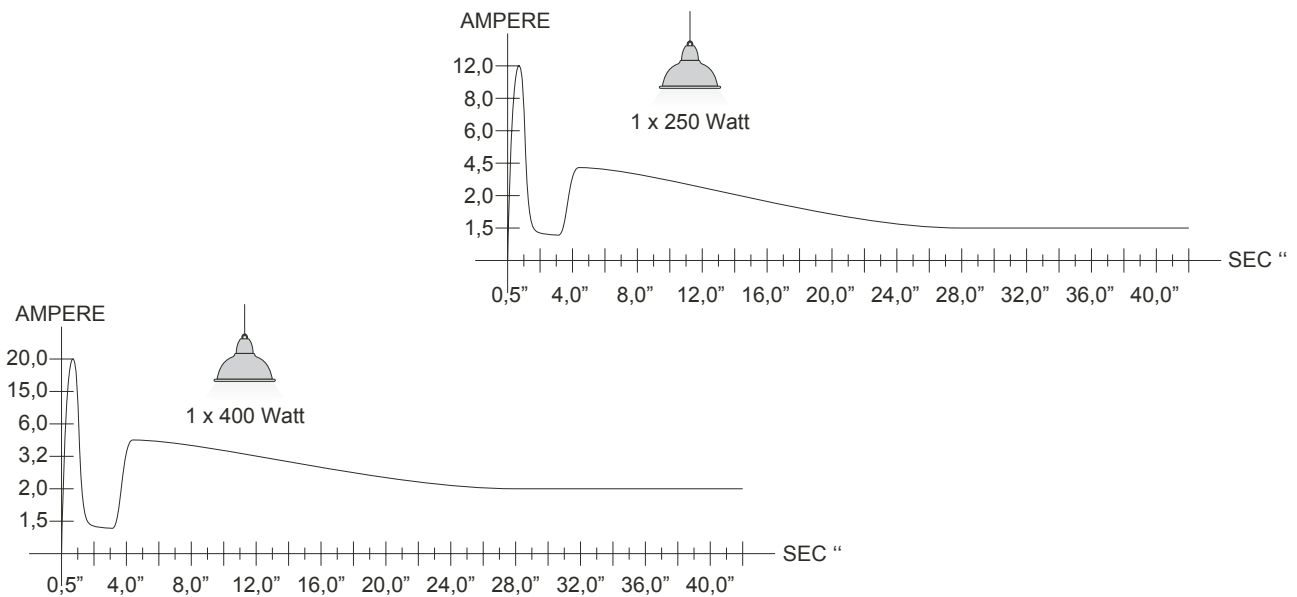
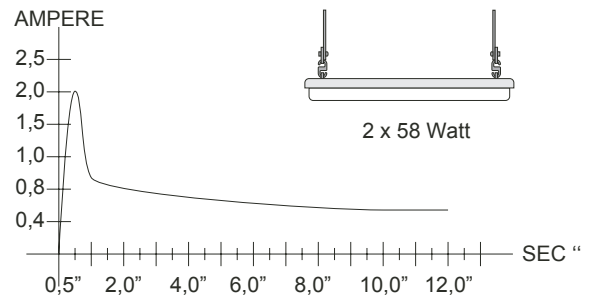
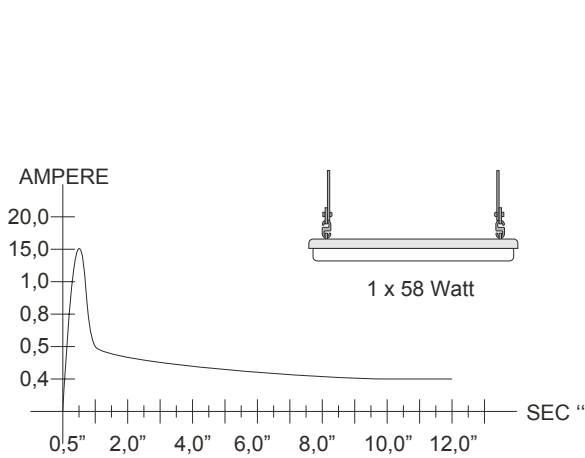

EN 60439-1-2



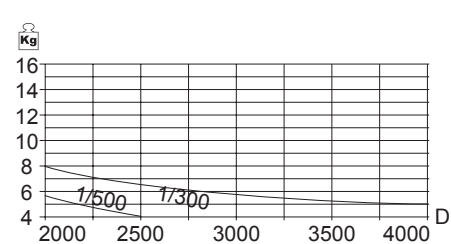
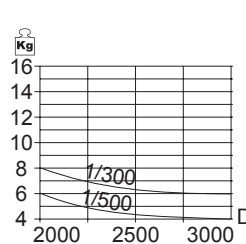
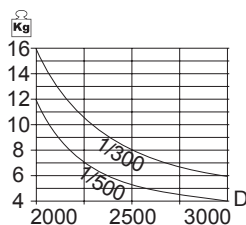
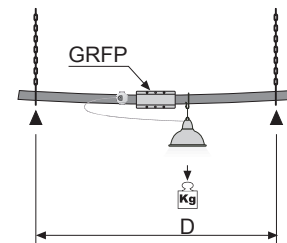
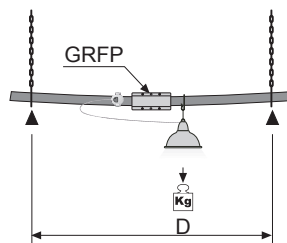
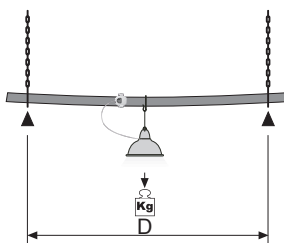
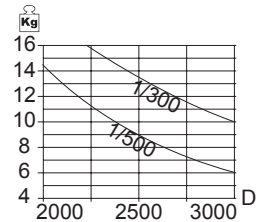
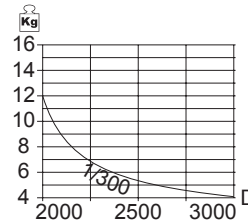
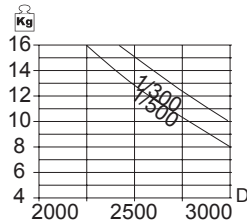
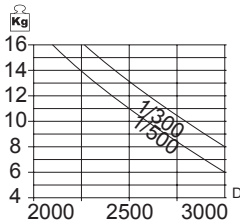
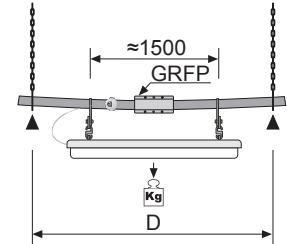
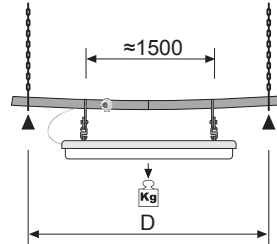
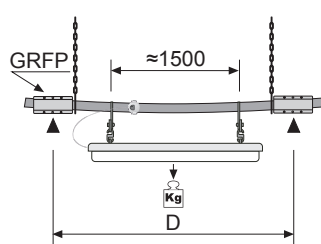
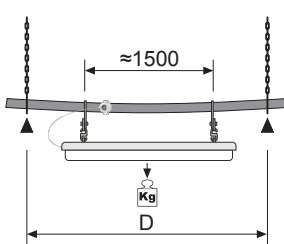
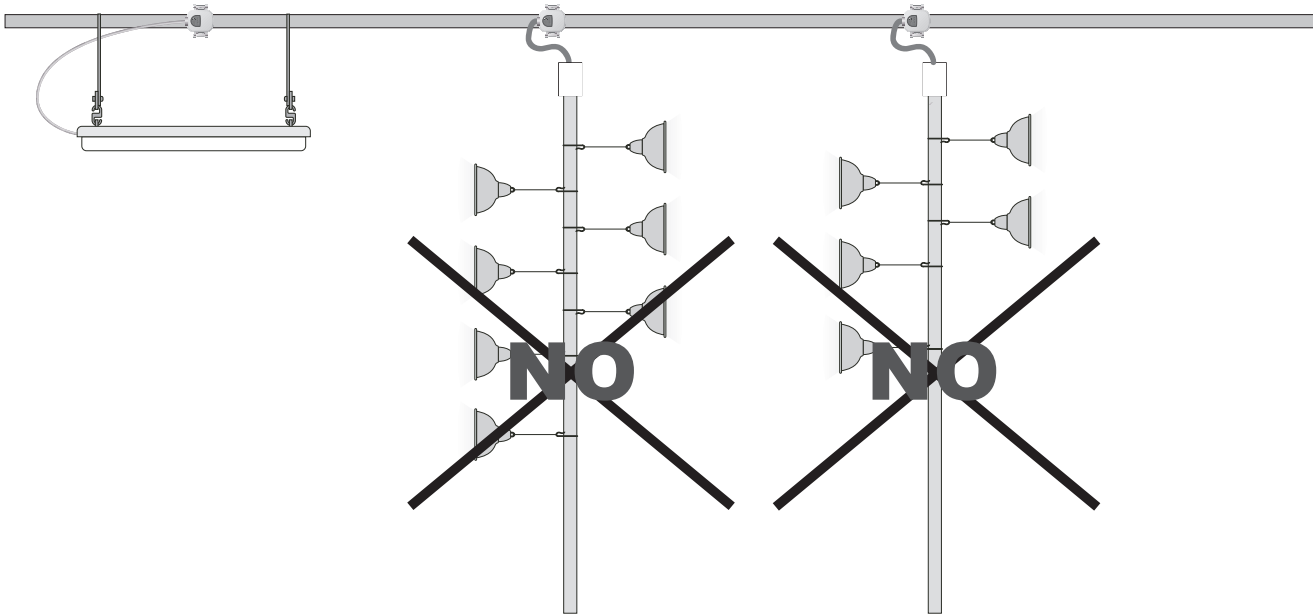

EN 60439-1-2

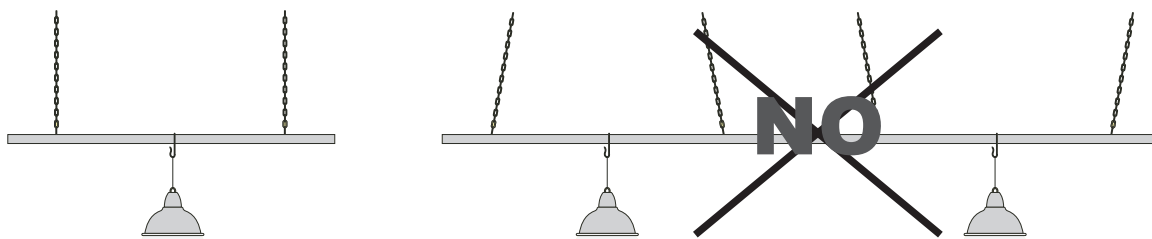
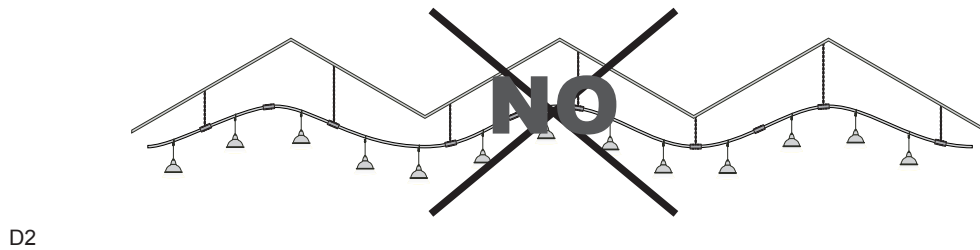
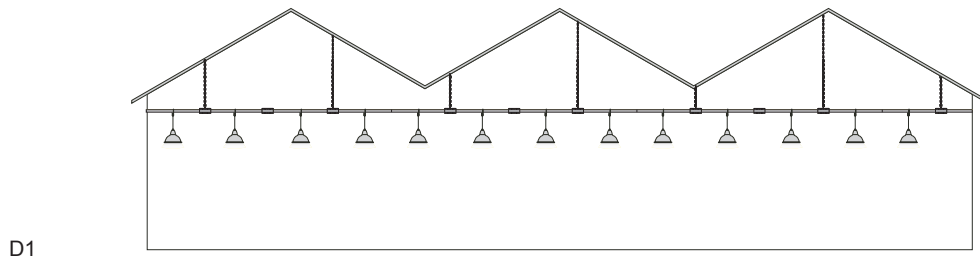
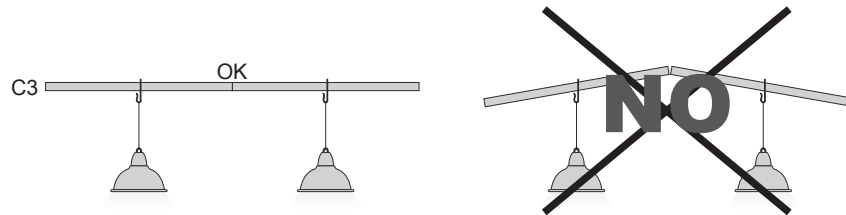
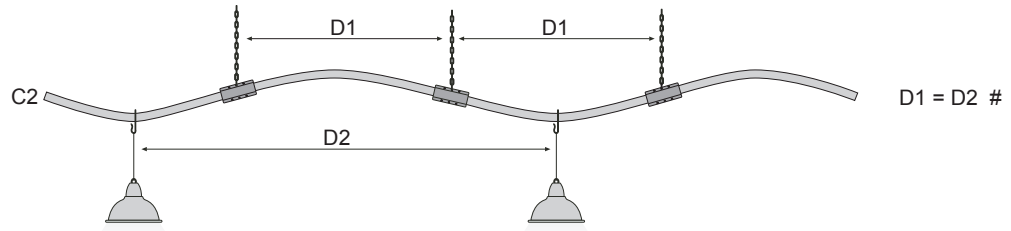
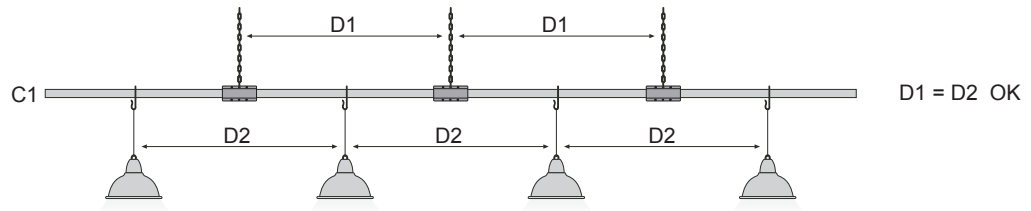

# NAXSO FLOOR

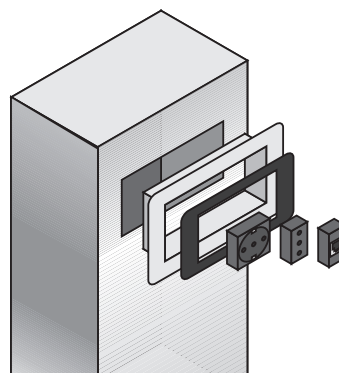
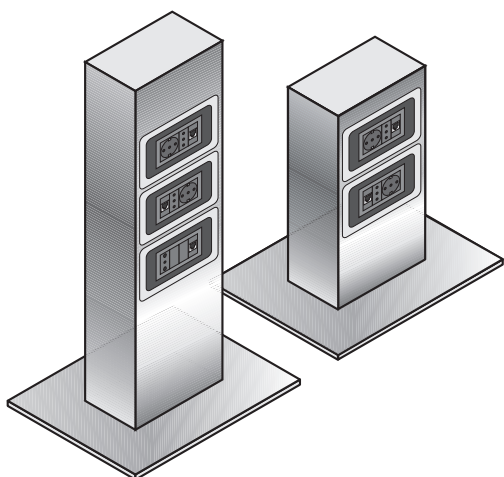
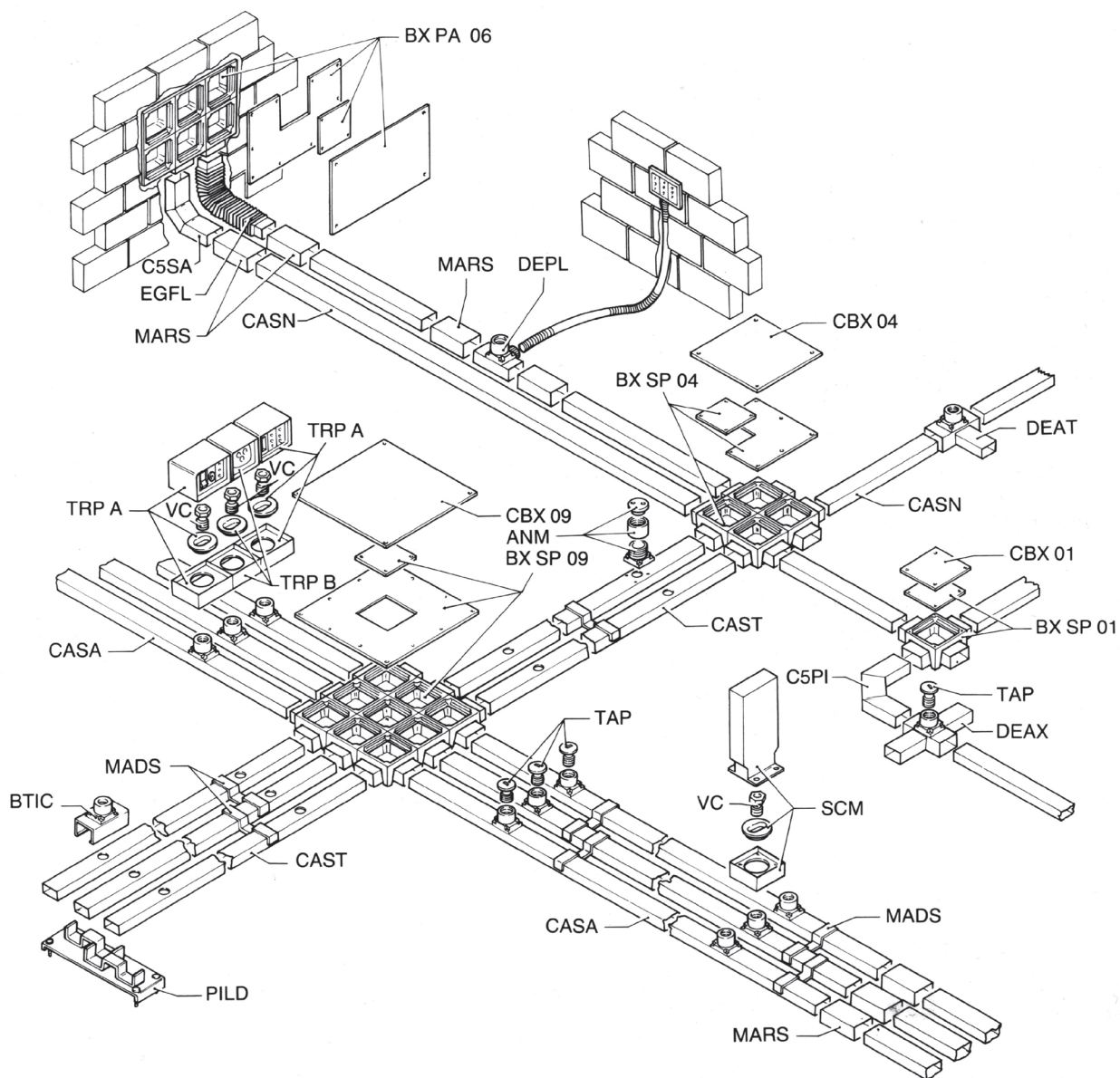

NAXSO FLOOR

**TOTEM A/B**



**TOTEM C/D**

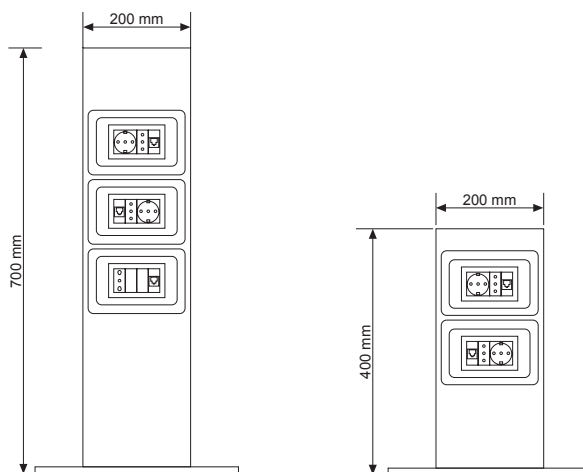

**TRP/A**



Art.	A	B
TRG/A	152	85
TRG/B	122	60

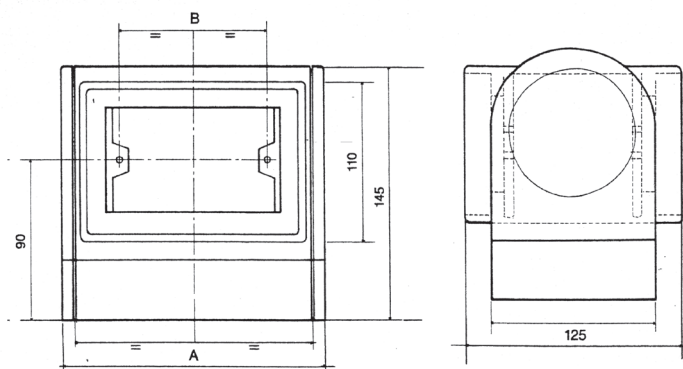

**TRG/A**



Art.	A	B
TRG/A	152	85
TRG/B	122	60

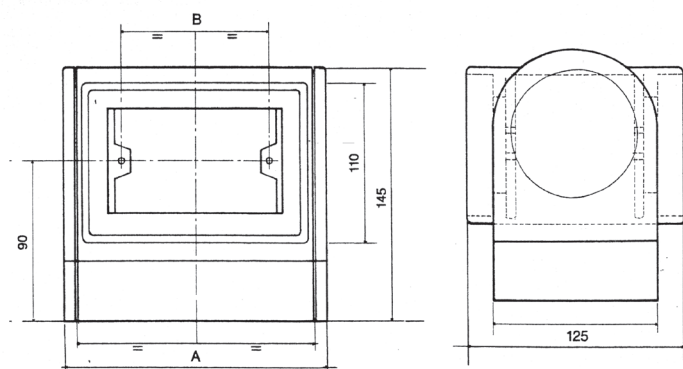

**TRG/A**



Art.	A	B
TRG/A	152	85
TRG/B	122	60

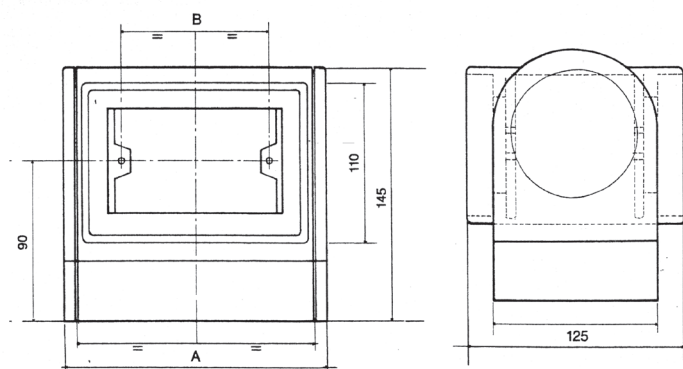

**CASA/N/T**

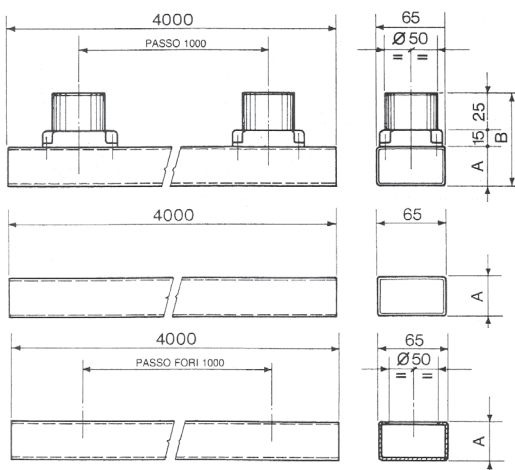

Art.	A	B
CASA 10025	25	65
CASA 10030	30	70
CASA 10035	35	75

Art.	A
CASN 25001	25
CASN 30001	30
CASN 35001	35

Art.	A
CAST 25001	25
CAST 30001	30
CAST 35001	35

EN 60439-1-2

**EGFL40035**

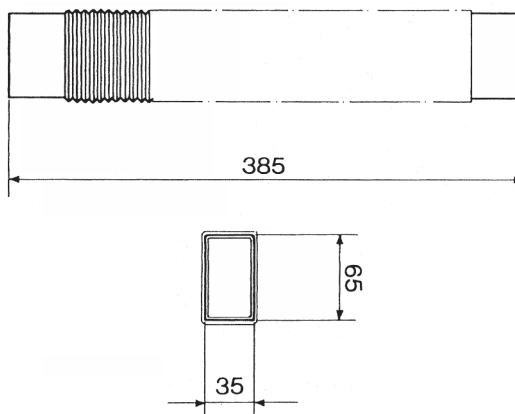

**MADS25001**

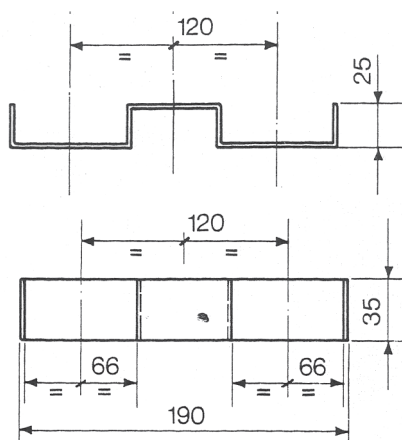

**DEPL.....**



Art.	A	B	Tube
DEPL 25001	25	65	16/19
DEPL 30001	30	70	16/19
DEPL 35001	35	75	16/19

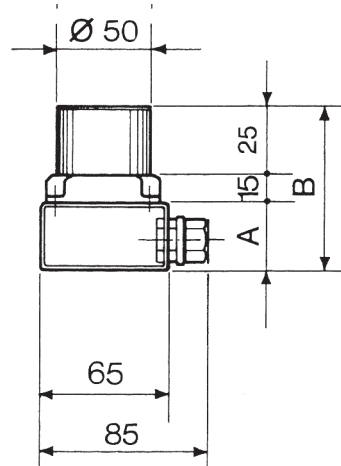
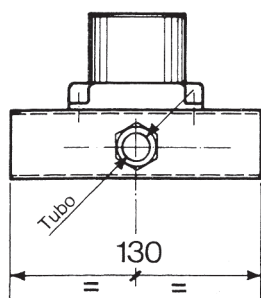

**BTIC.....**

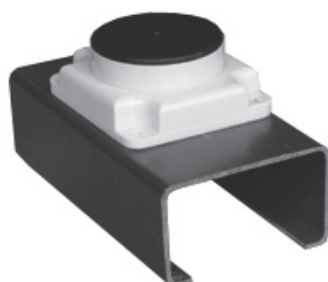

Art.	A	B
BTIC 25001	30	70
BTIC 30001	35	75
BTIC 35001	40	80

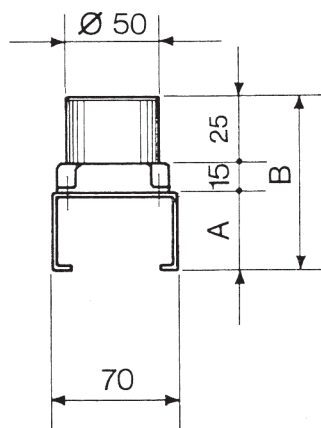
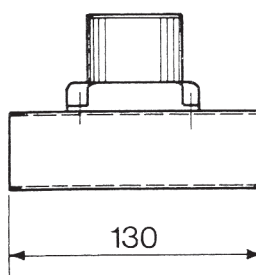

EN 60439-1-2

**MARS.....**

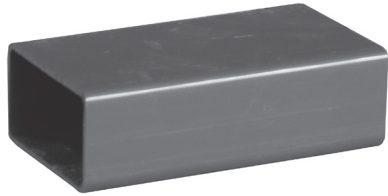

Art.	A
MARS 25001	30
MARS 30001	35
MARS 35001	40

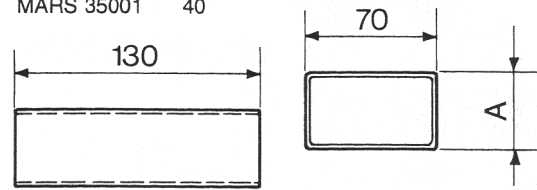

**C5PI.....**



Art.	A
MARS 25001	30
MARS 30001	35
MARS 35001	40

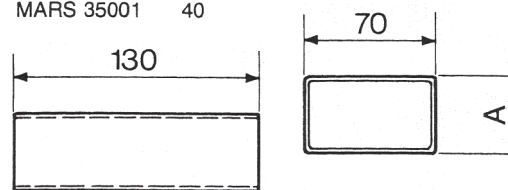

**C5SA.....**



Art.	A
C5PI 25001	25
C5PI 30001	30
C5PI 35001	35

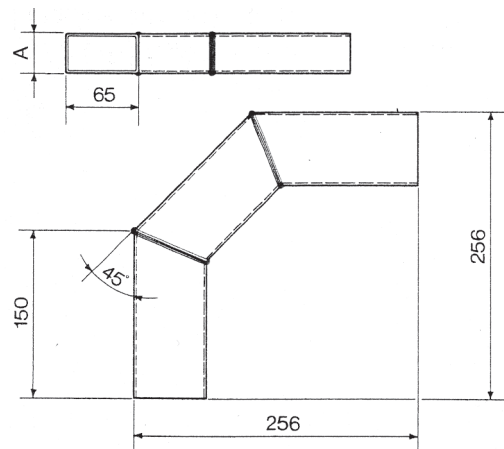

**BXSP01**

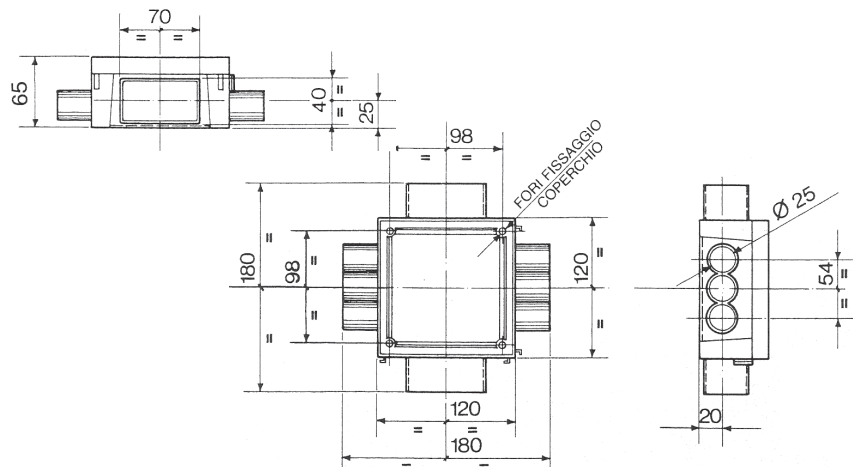

EN 60439-1-2



**CSSP02**

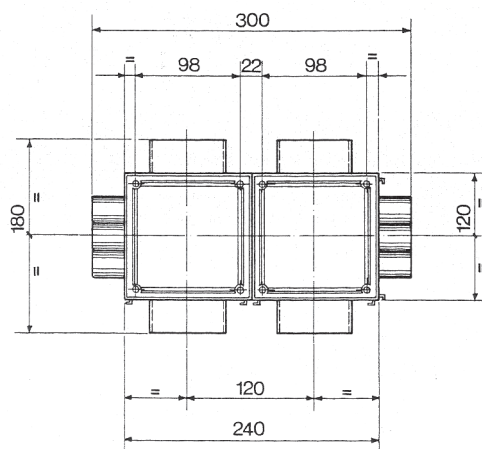
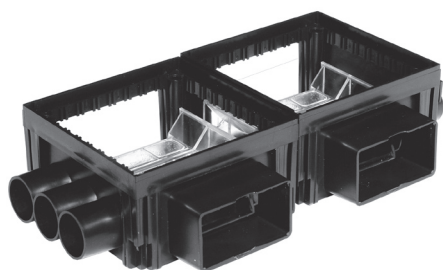

**CSSP03**

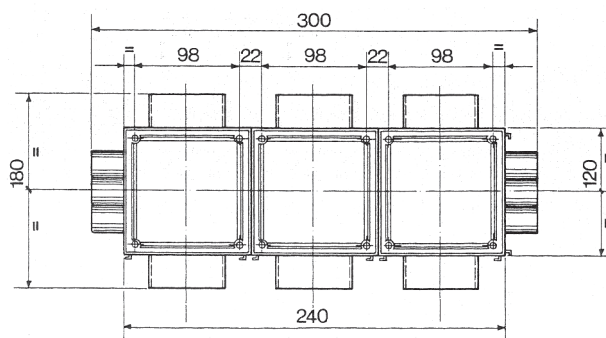
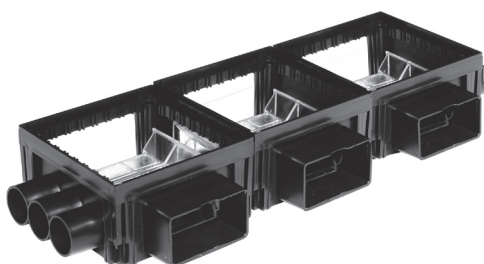

**BXSP04**

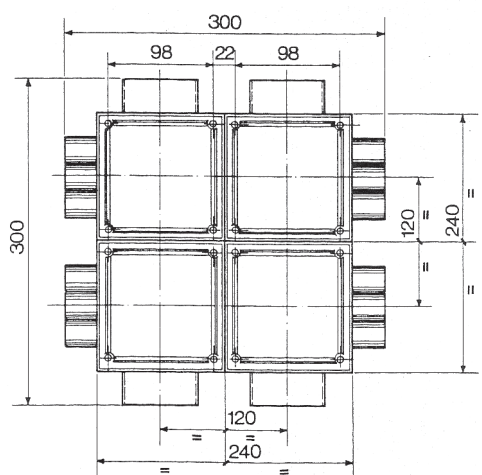
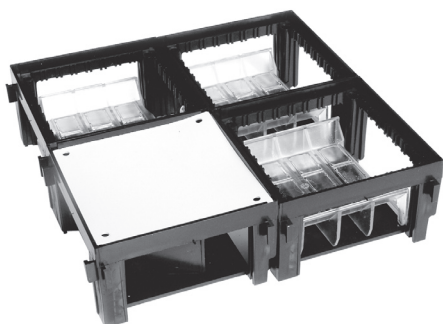

**BXSP09**

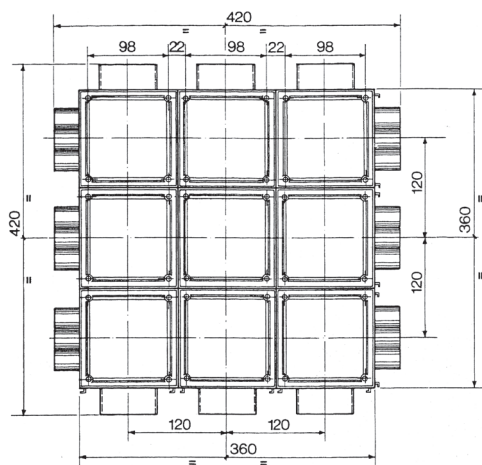
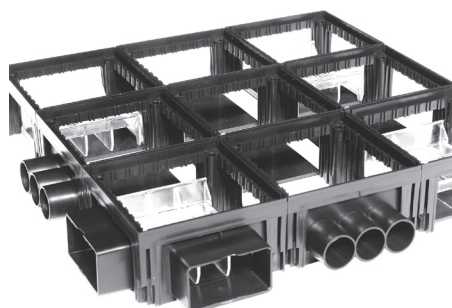

EN 60439-1-2

**CCS.....**

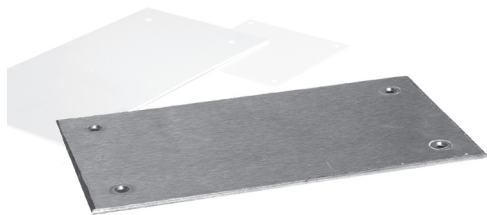

Art.	A	B
COP. CS02 ACC./OTT.	266	218
COP. CS03 ACC./OTT.	386	338

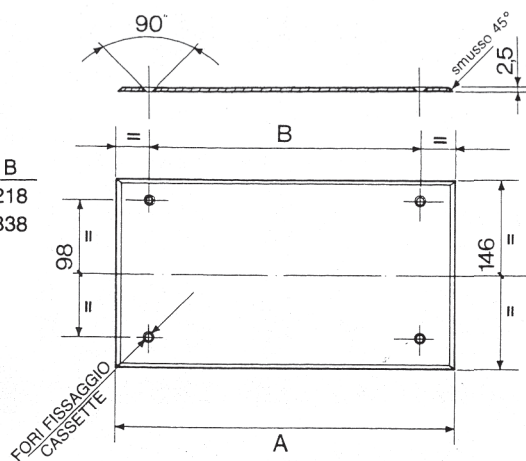

**CBX.....**

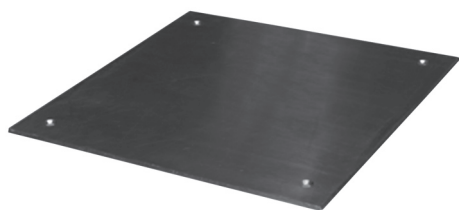

Art.
CBX01 ACC./OTT.
CBX04 ACC./OTT.
CBX09 ACC./OTT.

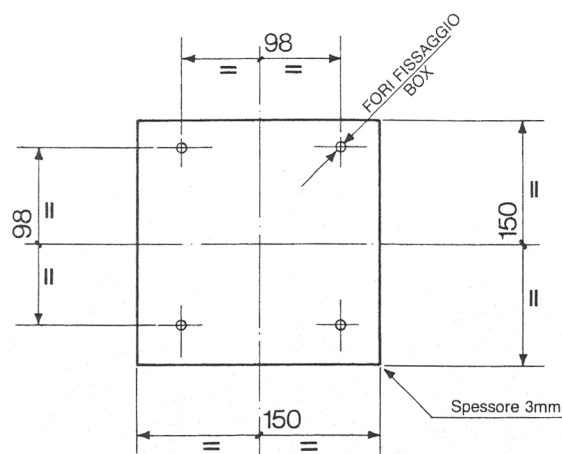

**VC.....**



Art.	A	B
VC 035	35	45
VC 050	50	60
VC 070	70	80
VC 100	100	110

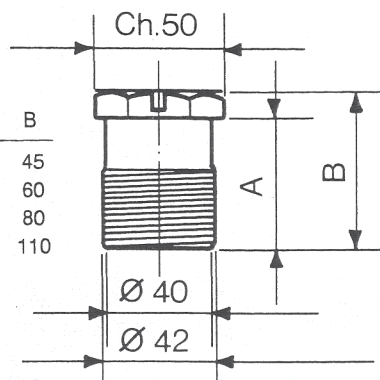

**TAP.....**



Art.	A
TAP 35 PVC	35
TAP 50 M	50
TAP 60 PVC	60
TAP 100 PVC	100

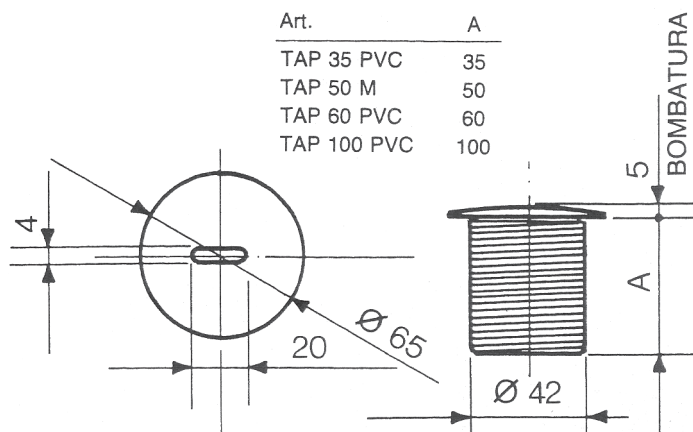

EN 60439-1-2